

Datasheet

Infiniturn® Encoder mab50AP

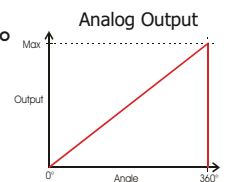

- Configurable angular range and rotational direction
Type mab50APS (Singleturn): up to 360°
Type mab50APM (Multiturn): up to 200x360°
- 12 Bit resolution
- Analog Output: 0-10V, 4-20mA
- Supply voltage: 24V
- 2 Precision ball bearing



The starting and end angle as well as rotary sense can be programmed in your application by Programm lines. On the Type mab50APM the counter reading of up to 200 turns is filed in a nonvolatile memory chip.



**Infiniturn® Encoder
mab50AP**

Possible combinations

Type	Resolution	Supply voltage	output
MAB50AP	12	5V	0-5V, ratiometric
	12	12V (9-30V)	0-5V
	12	24V (15-30V)	0-5V, 0-10V
	12	12V, 24V (8-30V)	4-20mA
	12	12V, 24V (8-30V)	0-20mA

Please note:

Not every combination is possible. Please refer to above table.

All sensor can be programmed by your self: Angles, output signal, signal direction and so on.

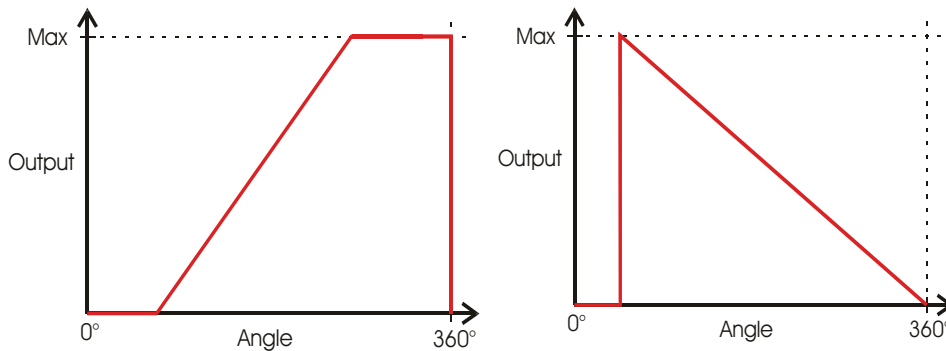

MegaMotive GmbH & Co. KG

Hermann-Oberth-Str. 7
85640 Putzbrunn / Munich
Germany
Tel.: +49 (0) 89 460 94 - 132
Fax: +48 (0) 89 460 94 - 287
www.megamotive.de
sales@megamotive.de

(*)

For more Options, please refer to our configuration sheet

Please note
The specifications and informations in this datasheet cannot consider all special demands that are caused by the application. Because of this, they are no general description of the properties of the product. Please also consider our detailed specifications.



**Infiniturn® Encoder
mab50AP**

Standard Options and Order Description

Type	Singleturn Multiturn	Resolution Speed	Supply Voltage	Output Signal	Order description
MAB50AP	S = Singleturn	12 Bit	24V	0 - 10V	MAB50APS 12 2410
				4 - 20mA	MAB50APS 12 2442
	M = Multiturn			0 - 10V	MAB50APM 12 2410
				4 - 20mA	MAB50APM 12 2442

All Standard Versions have an 360° angle and the signal direction is CW (clockwise) with M12 connector.
For programming the Sensor, please see our application note.

MAB50APS standard analog output 360° cw

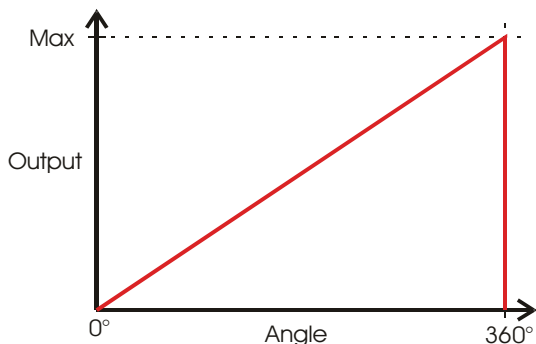

MAB50APM standard analog output 3600° cw

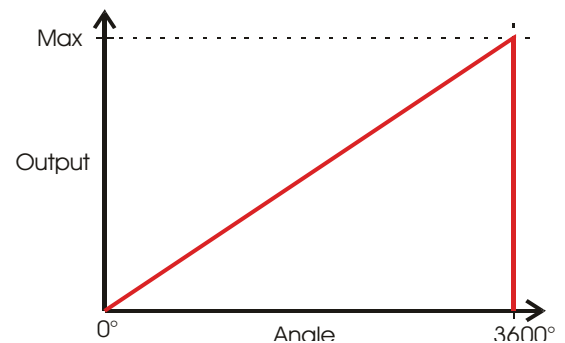

Our speciality are customs solutions, economically priced on small series.
Mechanical: 6 pole Cable, special shaft, mounting of gear wheels and other mechanical parts.
Electrical: Please refer to our **configuration sheet**.

**Infiniturn® Encoder
mab50AP****Electrical Specifications**

	mab50AP S	
Electrical angle		45° - 360°
Independent linearity tolerance		± 0,3%
Resolution		4096 Steps (360°) = 12 Bit e.g. 45° = 9 Bit
Updaterate position		1,1 ms
	mab50AP M	
Electrical angle		45° -X x 360° (e.g. 200x 360°)
Independent linearity tolerance		± 0,3%
Resolution		4096 Steps (360°) = 12 Bit e.g. 360° = 9 Bit
Updaterate position		3,7 ms
	Voltage Output	
OutputSignal		0-10V
Supply voltage		15 - 30 VDC
Power consumption		<20mA (no load)
Output resistance		>5 KΩ
	Current Output	
OutputSignal		4-20mA
Supply voltage		8 - 30 VDC
Power consumption		<20mA (no load)
Output resistance		>500 Ω

MegaMotive GmbH & Co. KG

Herrmann-Oberth-Str. 7
85640 Putzbrunn / Munich
Germany
Tel.: +49 (0) 89 460 94 - 132
Fax: +48 (0) 89 460 94 - 287
www.megamotive.de
sales@megamotive.de

For more Options, please refer to our configuration sheet



**Infiniturn® Encoder
mab50AP**

Mechanical Specifications

Housing	chormed aluminium	
Material Shaft	stainless steel	
Bearing	2 precision ball bearing	
Protection Class	IP65	
Operating temperature	-30 ... +80° C	
Storage temperature	-30 ... +80° C	
Dimensions	pls. find drawing at page 6	
Ø Shaft	Ø 12mm	(*1)
Max. rotational speed	6.000 turn/min	
Life expectancy	>50 Mio. turns	
weight	approx. 90 g	

Option M12 Connector

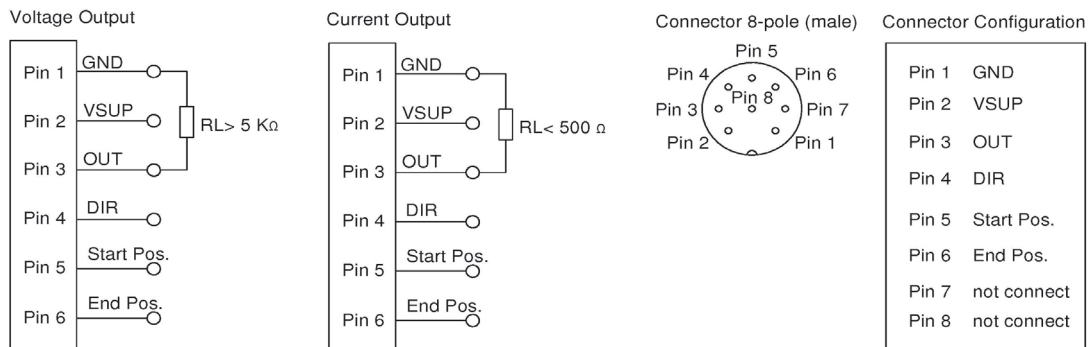

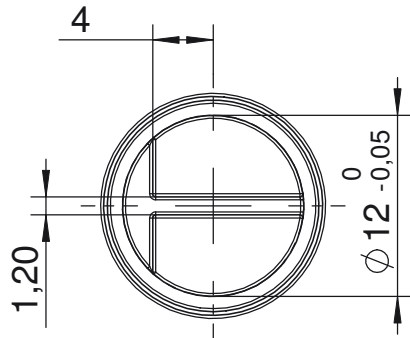
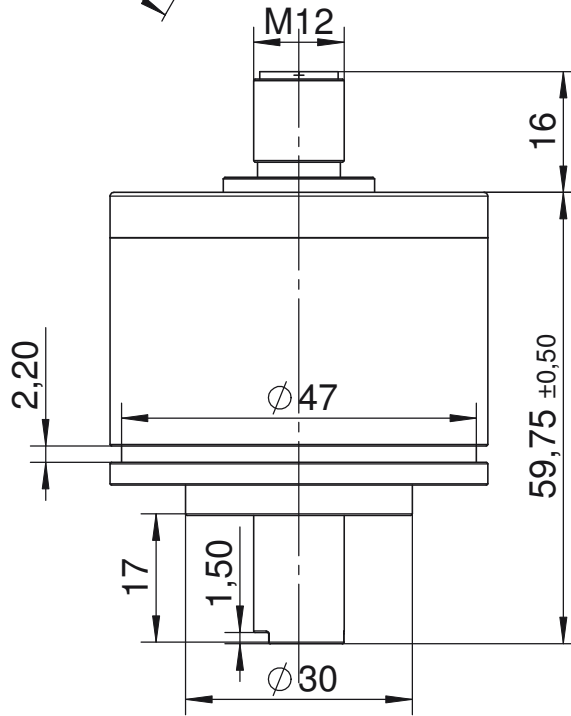
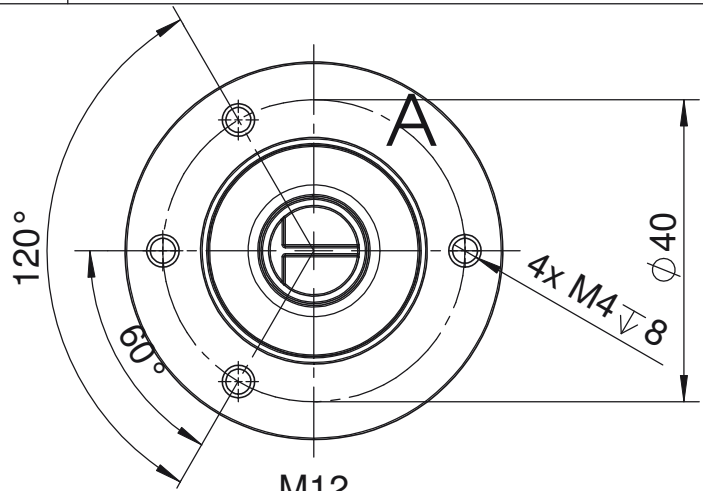
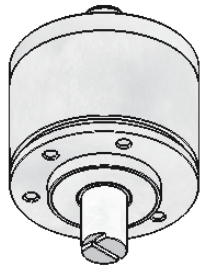

ANSICHT A
MAßSTAB 2 : 1

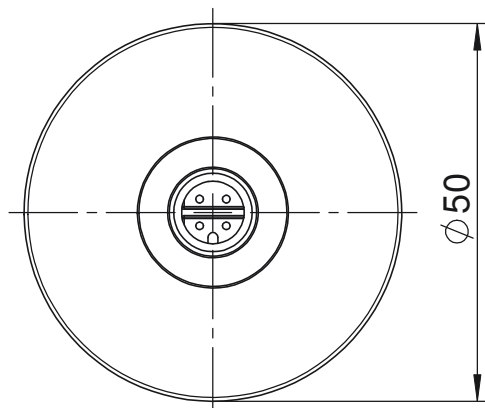

The copying, use, distribution or disclosure of the confidential and proprietary information contained in this document(s) is strictly prohibited without prior written consent. Any breach shall subject the infringing party to remedies. The owner reserves all rights in the event of the grant of a patent or the registration of utility model or design.

Die Weitergabe sowie Vervielfältigung dieser vertraulichen Unterlage(n), Verwertung und Mitteilung ihres Inhaltes ist ohne unserer vorherige schriftliche Genehmigung nicht gestattet. Zuwiderhandlungen verpflichten zu Schadensersatz. Alle Rechte für den Fall der Patenterteilung und Gebrauchsmustereintragung vorbehalten.

General Tolerances DIN 7168mH		Form and Coat Tolerances DIN/ISO 1101		Edges Dimension DIN 6784		Surface DIN/ISO 1302		Weight [g]													
		<table border="1"> <tr> <td>⊙</td> <td>0,1</td> </tr> <tr> <td>□</td> <td>0,05</td> </tr> </table>		⊙	0,1	□	0,05	<table border="1"> <tr> <td>↙</td> <td>+0 -0,1</td> </tr> <tr> <td>↘</td> <td>-0 +0,1</td> </tr> </table>		↙	+0 -0,1	↘	-0 +0,1	<table border="1"> <tr> <td>w</td> <td>✓ (✓)</td> </tr> </table>		w	✓ (✓)			Material	
⊙	0,1																				
□	0,05																				
↙	+0 -0,1																				
↘	-0 +0,1																				
w	✓ (✓)																				
								Surface													
Index	Modification	Date	Name	Date	Name	Title															
				Drw.	07.11.2008	DB R50															
				Chkd..	07.11.2008	00085_R50_komplett_4_00_00															
				Norm		Project Number															
						00085			Sheet 1												
									of 1												
Megamotive GmbH & Co. KG Hermann-Oberth-Str. 7 85640 Putzbrunn / München Telefon: 089/46094-0 info@megamotive.de / www.megamotive.de						Format	DINA4			Scale: 1:1											

Application Note

R50APS, R50APM

How to program the R40APS and R40APM

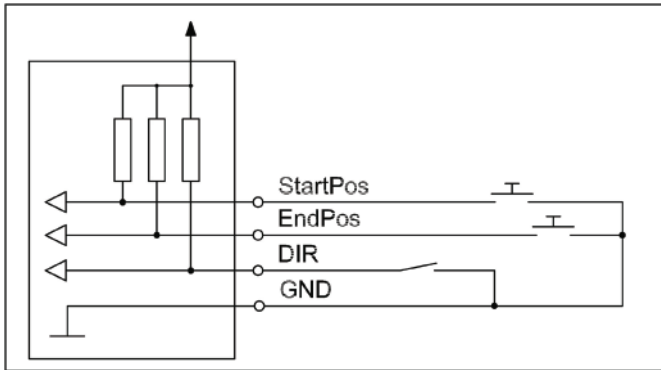

Figure 1: Programming

1. Factory Setting

Singleturn version R50APS:

The analog output signal (0-10V / 4-20mA) rise at clockwise rotation (CW) over a full turn of 360°

Multiturn version R50APM:

The analog output signal (0-10V / 4-20mA) rise at clockwise rotation (CW) over 10 revolutions. Internal pull-up resistors keep the control lines at a defined high level. Further movement after reaching the full scale value will cause the encoder to toggle down to the minimum value and continue the output signal periodically.

2. Reset and zero point setting

Please note: The sequential order of the following programm steps is essential!

Incorrect order or incomplete programming may cause undefined sensor states. In this case the sensor must be rested.

To reset the Sensor push the buttons StartPos and EndPos for more than 2 seconds (pls. see figure 2).

This settles the zero value (0V / 4mA) at the current sensor position.

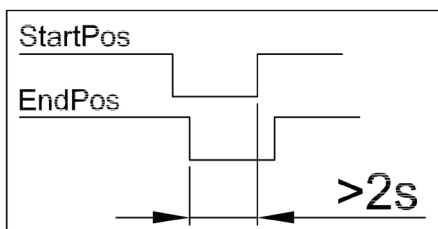

Figure 2: Timing reset

MegaMotive GmbH & Co. KG

Hermann-Oberth-Str. 7
85640 Putzbrunn / Munich
Germany
Tel.: +49 (0) 89 460 94 - 132
Fax: +48 (0) 89 460 94 - 287
www.megamotive.de
sales@megamotive.de

Application Note

R50APS, R50APM

3. Setting the rational direction

A low level at the DIR line will change the output signal to increase in CCW-direction.
Please note: Modifications of the DIR line are updated on reset only.

4. Setting the Start Position and the End Position

- 4.1. Reset the sensor
- 4.2. Move the sensor to the Start Position
- 4.3. Press the Start button for more than 2 seconds
Now the output value is set to minimum
- 4.4. Move the sensor to End Position
- 4.5. Press the End button for more than 2 seconds
Now the output value is set to maximum.

Please note: The above sequence has to be completed from 4.1. to 4.5.

The sensor is now programmed according to the angle between Start and End Position. When the sensor is moved beyond end Position, the output signal will continue periodically after reaching the next full revolution.

Between End Position and next full revolution the remaining angle is parted in two sections.

During the first section the max. value is output.

During the second section the min. value is output (pls. see figure 3).

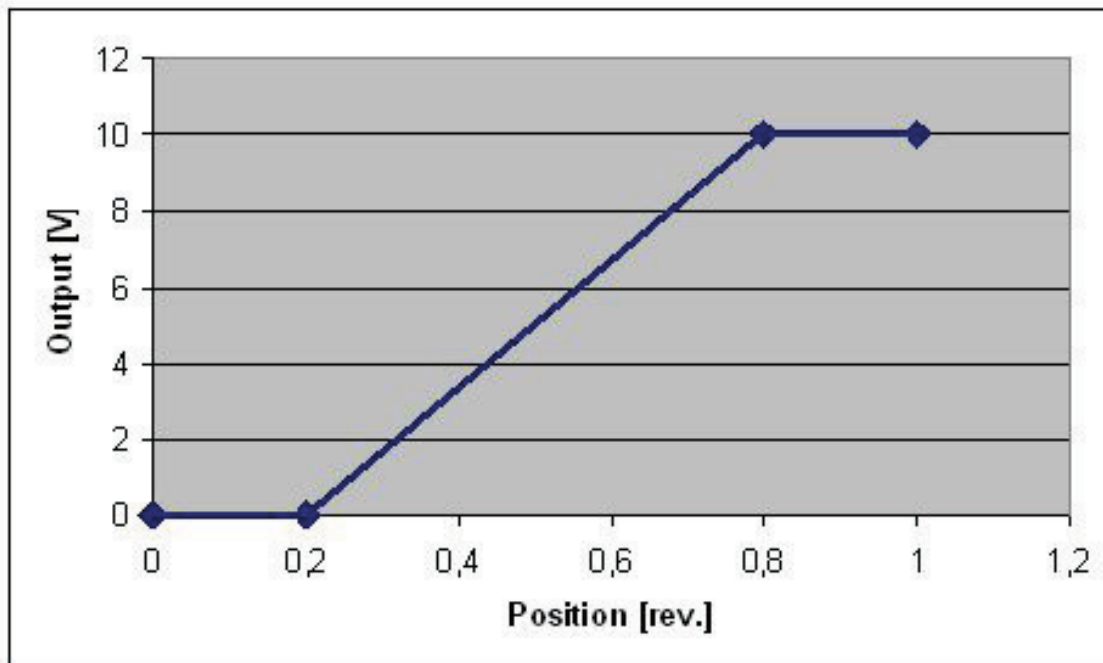

Figure 3:
Example for the output voltage for a Start Position of 72° and an End Position of 288°

Security advice:

The programming of the sensor has to be done by authorized personnel only!

MegaMotive GmbH & Co. KG

Hermann-Oberth-Str. 7
85640 Putzbrunn / Munich
Germany
Tel.: +49 (0) 89 460 94 - 132
Fax: +48 (0) 89 460 94 - 287
www.megamotive.de
sales@megamotive.de