

MRSi-x400 & MRTi-x400



**3U Plastic Box printer
with EPSON dotmatrix
mechanism**

- **Printing mechanism**
 - Dot-matrix technology in 144, 192 or 240 dots/line
 - 4 or 8 needles shuttle printer
 - MRSi: printer with Epson M-160 mechanism
 - MRTi: printer with EPSON M-190 mechanism
- **Interface**
 - TTL serial or RS232C from 110 to 19k2 baud
 - USB 2.0 Printer Class
 - Ethernet
- **Power Supply: DC 5 V, DC 9-40 V or Mains**
- **Characteristics**
 - 3U Plastic Case
 - Self-test and hexadecimal dump
 - 2 characters fonts
 - Graphic curve mode
 - Horizontal line graphic mode.
 - Real time clock
with summer / winter adjustment

SUMMARY

| | | |
|-------|--|----|
| 1 | Generality..... | 3 |
| 1.1 | Functioning..... | 3 |
| 1.2 | Material description..... | 4 |
| 1.3 | Part number..... | 5 |
| 1.4 | Technical Data..... | 6 |
| 2 | Printer Operation..... | 7 |
| 2.1 | Start-Up..... | 7 |
| 2.2 | System Reinitialization (RESET)..... | 7 |
| 2.3 | Self-test or Hexa Dump..... | 7 |
| 2.4 | Plastic Case (MRxi-x4xx)..... | 8 |
| 2.4.1 | Paper End..... | 8 |
| 2.4.2 | Status Led..... | 8 |
| 2.4.3 | Paper change without lost of data..... | 9 |
| 2.4.4 | Fixing..... | 10 |
| 2.4.5 | Size..... | 10 |
| 3 | Driver installation..... | 11 |
| 3.1 | Windows..... | 11 |
| 4 | Wiring Information..... | 14 |
| 4.1 | Board connections..... | 14 |
| 5 | Configuration menu..... | 15 |
| 6 | Fonts & Control codes..... | 20 |
| 6.1 | Character Sets..... | 20 |
| 6.2 | Control codes PCL Raw..... | 20 |
| 6.3 | Control codes ESC/P 9 PINS..... | 21 |
| 6.4 | Control code ESC/P Basic..... | 21 |
| 6.5 | Control code MRS & MP-181..... | 22 |
| 7 | Annexe..... | 23 |
| 7.1 | Cables and Consumables..... | 23 |

1 GENERALITY

1.1 FUNCTIONING

Most of the printers available on the market allow printing data, text or graphic supplied by a computer or a PLC. When designing the MRSi and MRTi printers, we took into account many special requests from our customers in order to design the most universal O.E.M printer available today.

Several housings are available in order to integrate these printers on machine front panel or a 3U equipment

With its dotmatrix technology, this printer is the right solution for tracability applications, when a long preservation of the ticket is required.

Many features are included in the printer software allowing graphic printing and a lot of special effects:

Bonus:

- Compatibility: with printer language like Epson ESC/P 9 pins, HP PCL Raw or Megatron MRS
- 2 character fonts in 6x10 and 10x10 matrix
- Selftest and Hexadecimal dump to debugging the interface
- Windows 2K / XP and Vista 32 driver available on our website www.megatron.fr.

AGREEMENTS

Because of the evolution of standards and technologies and in a permanent concern of improvement, the contents of this manual are subject to change without notice.

1.2 MATERIAL DESCRIPTION

The printer is designed around a PSD3434E microprocessor, with 7K-Bytes of RAM available for buffering datas. An internal watchdog in the microprocessor is activated to insure an operation in strongly polluted industrial environment.

Printing heads: 2 kinds of head can be used :

- MRSi printers are equipped with Epson M-160 dot-matrix head family with 4 needles allowing slow graphic printings with long delay between lines
- MRTi printers are equipped with Epson M-190 dot-matrix head family with 8 needles allowing fast text or graphic printings

Serial Interface: The printer can be connected in serial in TTL or RS232C levels. Hardware (RTS/CTS) and software (XON/XOFF) handshakes are simultaneously supported.

USB 2.0: The printer can be connected in USB 2.0 at full speed. Printer class (class 7) is supported.

Accessories: Several accessories like Line-Feed button, control LED, paper-end detector and rewinder are directly managed by MRSi and MRTi printers.

Power Supply: Depending of the model, VCC power supply must be supply in DC 5 V, DC 9 to 40 V or Mains.

1.3 PART NUMBER

Several versions of the electronics and cases are available. To completely define your product, it is necessary to add a suffix to the name of the printer to specify the printer type, the selected computer connection, the power supply and the clock option.

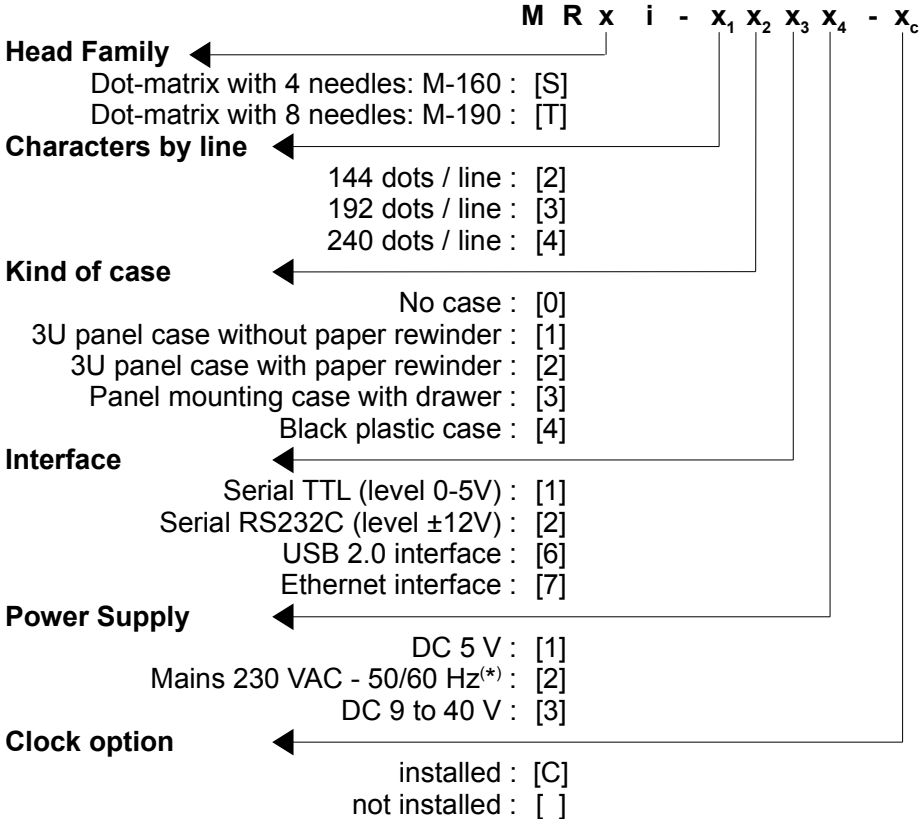

(*) Mains supply is actually under development. Any order of a MRxi-xxx2 will be temporarily delivered with MRxi-xxx1 with a separated Mains Supply.

1.4 TECHNICAL DATA

| | |
|---------------------|---------------------------------|
| Serial Interface | TTL serial RS232C/V24 serial |
| Handshake | Xon/Xoff and RTS/CTS |
| USB Interface | USB 2.0, Printer Class |
| Working temperature | 0 to 50°C |

| | | | | |
|---------------------------------------|--------------|----------------|--------------|-----------------|
| Power supply (model depending) | 5 VDC | 9-40VDC | 5 VDC | 9-40 VDC |
| Consumption | at 5V | at 12V | at 5V | at 12V |
| Waiting | < 0,1A | < 0,1A | < 0,1A | < 0,1A |
| Average | 0,8 A | 0,5 A | 2,5 A | 0,7 A |
| Peak | 1,5 A | 1 A | 5,5 A | 2,3 A |
| Model | MRSi | MRSi | MRTi | MRTi |

| | MRSi | | | MRTi | | |
|---------------------|-----------|-----------|-----------|-----------|-----------|-----------|
| | 2xxx | 3xxx | 4xxx | 2xxx | 3xxx | 4xxx |
| Print Heads | | | | | | |
| Reference | M-160 | M-161 | M-162 | M-190 | M-191 | M-192 |
| Dots / line | 144 | 192 | 240 | 144 | 192 | 240 |
| Text printing speed | ~ 0,7 l/s | ~ 0,5 l/s | ~ 0,4 l/s | ~ 2,5 l/s | ~ 1,9 l/s | ~ 1,5 l/s |
| MCBF (lines) | ~ 500K | ~ 500K | ~ 500K | ~ 1 500K | ~ 1 100K | ~ 900K |

| Character Set IBM-II in matrix 6 x 10 dots (v*h) | MRSi & MRTi | | |
|---|-------------|------|------|
| | 2xxx | 3xxx | 4xxx |
| Chars/line | 24 | 32 | 40 |
| Chars. width (mm) | 2,0 | 1,5 | 1,2 |
| Chars Height (mm) | 2,6 | 2,6 | 2,6 |

| Character Set IBM-II in matrix 10 x 10 dots (v*h) | MRSi & MRTi | | |
|--|-------------|------|------|
| | 2xxx | 3xxx | 4xxx |
| Chars/line | 14 | 19 | 24 |
| Chars. width (mm) | 3,3 | 2,5 | 2,0 |
| Chars Height (mm) | 2,6 | 2,6 | 2,6 |

2 PRINTER OPERATION

2.1 START-UP

1. Connect the power supply and connection cables
2. Turn power on

The interface will control its memory, set its parameters according to the data menu stored in its Flash memory, look for the possible presence of a clock circuit and moves the printing head for one line to determine the dot number of the connected head. At the end of this initialization cycle, the printer is ready for receiving characters.

2.2 SYSTEM REINITIALIZATION (RESET)

The printer is designed with a watchdog which makes a reset at power-up authorizing the use of a slow ascent supply. About 300 milli-seconds after the controller is powered-up, this one is ready for operation, having ended its reset cycle.

2.3 SELF-TEST OR HEXA DUMP

If, after a reset or at power-up, the linefeed button is maintained pushed, a self-test cycle is run. The printer prints its name. At this time if you :

- continue pressing the LF button, the hexadecimal dump mode is invoked. A message 'DUMP HEXA MODE' is printed. Release the LF button. Now the value of all the received data will be printed in Hexadecimal followed by their ASCII value if printable. Power-off the printer to leave this mode.
- release the LF button, all the parameter settings and the character set are printed. At the end of the self-test the printer will work normally.

```
MRTi PRINTER
-----
 8 needles mechanism

SOFTWARE: F196v0.2

Downloaded Area
contains Messages

Clock
No Clock
Printer
Font      : Std_L6x10
Direction : TEXTMODE
Nat. Chars : USA
Width     : Width x1
Height    : Height x1
Serial
Baud      : 19k2 Baud
```

The self-test gives only a probability of correct operation of the printer; indeed, the self-test procedure does not use transmission, this one can only be tested in real mode.

2.4 PLASTIC CASE (MRxi-x4xx)

This printer integrate a printing head and the reserve of paper into an injected plastic case in black color. This case can be mounted in a panel thanks of four screws or in 3U system rack (dimensions 129 x 121,5 mm).

The interface is fixed at the back of the case making an autonomous and compact product.

2.4.1 Paper End

If a paper-end occurs, the red LED will blink and the printout is hanging. Depending of the « No Paper » menu setting, the paper defect can :

- be totally ignored (ignored)
- stop the printout but can accept the data until the buffer is full (Fill Buff.)
- stop the printout and stop the data transmission (Set Busy)

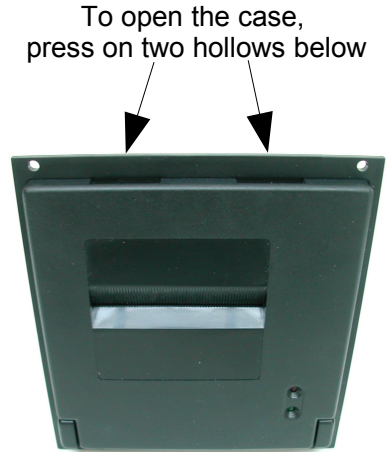

2.4.2 Status Led

A status LED informs the user of the possible defects of operation. When this led is out, it indicates a correct operation, a blinking LED indicates an abnormal status which is explained in the table below:

| LED Cycle | Description | System |
|------------------|----------------------|--------|
| ●●●●●●●●●●●●●●●● | Correct operation | No |
| ●○●○●○●○●○●○●○●○ | Paper End | No |
| ●●●●●●●●●○●○●○●○ | Printing head defect | Yes |
| ●●●●●●●●○●○●●●● | RAM memory defect | Yes |
| ●●●●●●●●○●●●●●● | Menu activated | Yes |

LED period : 80 msec .

The user can drive directly the red LED with the software command. But the 'system' status is priority and can't be inhibited.

2.4.3 Paper change without lost of data

- Open the case by pressing the two hollows at the opposite side of the hinges
- Remove the old paper roll on its holder
- Make a frank cut at the end of the new paper roll
- Put the new roll on the case bonnet (don't put it on the paper holder)
- Insert the extremity of the paper between the two lips of the printing head. Make several paper advances while maintaining engaged the paper until the paper goes out of the printer.
- Introduce the paper axis into the new roll. Insert both into the paper holder.
- The printout will start where it was stopped !

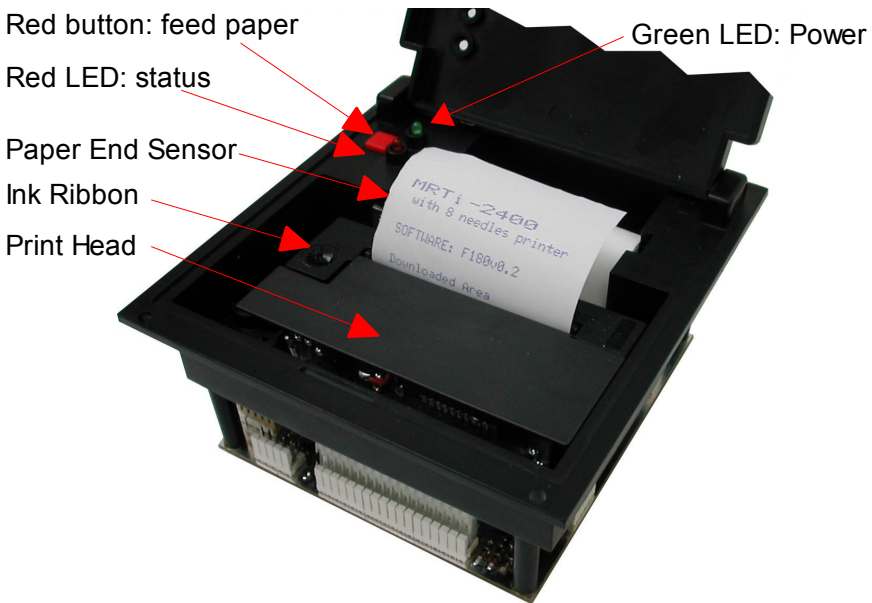

2.4.4 Fixing

The printer MRxi-x400 can be directly embedded in a panel where a window (109 x 110 mm) and 4 x M2,5 holes were practised.

Introduce the case by the front of the facade.

Screw the four fixation screws until obtain a freezing mechanics of the case against the panel.

2.4.5 Size

4 screws
M2.5

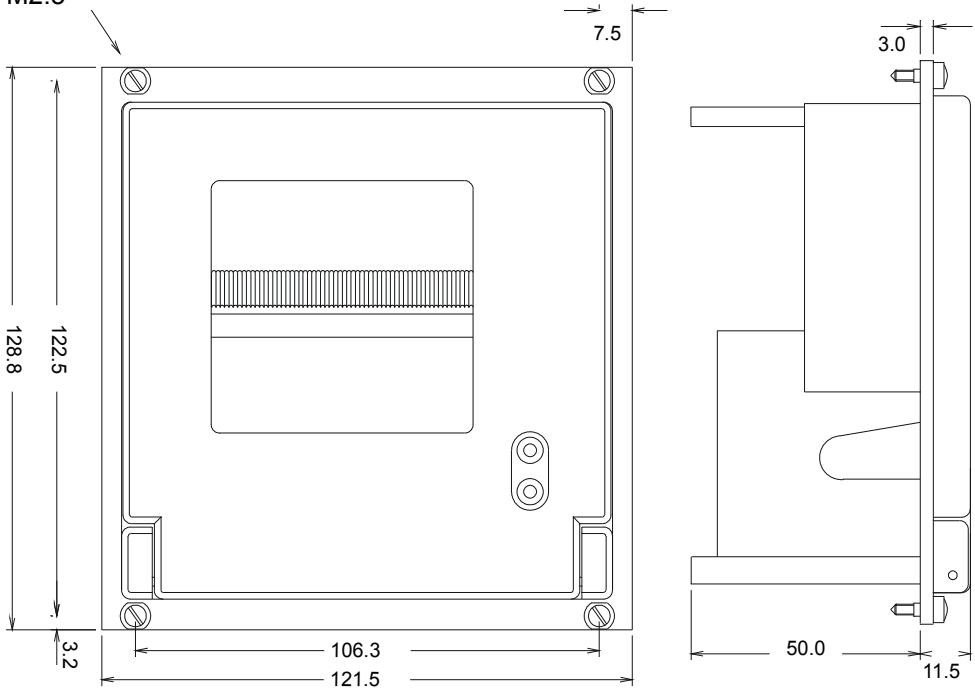

Total size with controller board: 121,5(w) × 129(h) × 72(d) mm

3 DRIVER INSTALLATION

3.1 WINDOWS

A windows driver for Windows 2000, XP, Vista32 is available on your website.

- Unzip it on a folder then connect the printer to your computer. Printer name used in the driver is the beginning of the printer reference; e.g.: MRSi-2, MRSi-3, MRSi-4, MRTi-2, MRTi-3, MRTi-4
- Add new printer and set the driver path with the folder path
- After installation, set the driver properties accordingly to your requirements.
 - Paper Size: Roll 58x82 mm, Roll 58x150 mm, Roll 58x210 mm
 - protocole: ESC/P 9pins, ESC/P Basic, PCL Raw



- In the windows applications, set the paper size to 5,8 cm width with left and right margins at 0,5 cm. No Top and bottom margins are necessary.

Serial:

the printer is not automatically detected.

- click on "add new printer" in the Printer and Fax folder.
- Select a local Printer
 - In the 'Select Printer Port' window, select the right serial Port (Com1.. ComX)
- Then continue to install the printer driver as usual
- When the installation is finished, you must set the settings of the serial port accordingly with the printer in the the printer driver properties : Baud rate, Data Bits, Parity, Stop bits, Flow Control.

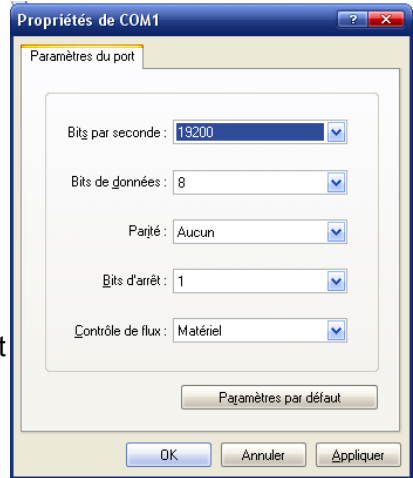

Don't forget to set the Flow Control to **Hardware** or **Xon/Xoff**

USB:

When you connect an USB printer to windows (2K/XP/Vista32), the OS automatically detect it and will ask you to install the correct driver.

Ethernet: Driver installation is usual except that you need to install a new port on your computer.

- In the printer and Fax window, click on "add new printer".
- Select a local Printer
 - In the 'Select Printer Port" window, select "Create a new port" and choose "Standard TCP/IP Port"



- In the "Add Port" Window, fill "IP address" with the address you find previously in the Lantronic Device Installer or you fixed in chapter " Change Module Settings". A name is automatically filled, you can change it if you want.

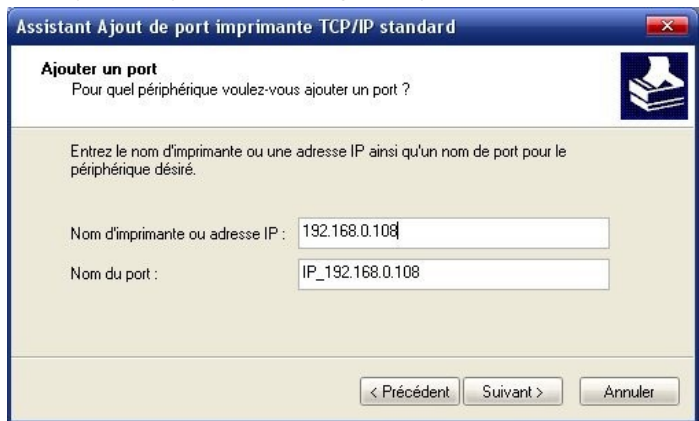

- In the "More Port Information are necessary", select "Standard: Generic Network Card"
- Then continue to install the printer driver as usual

4 WIRING INFORMATION

4.1 BOARD CONNECTIONS

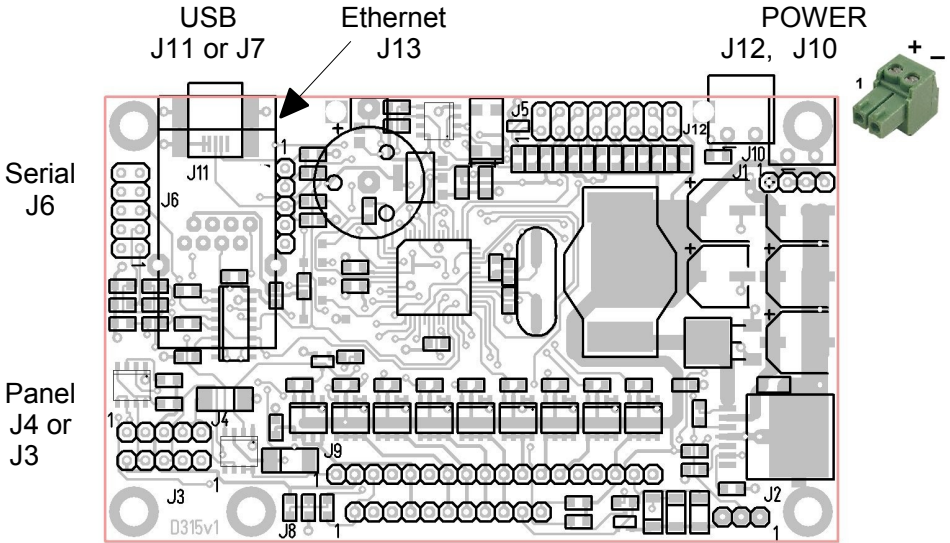

J9: 8 needles printer M-190 J2
 J8: 4 needles printer M-160

Fast connections

| | | |
|-------|-----------|--|
| POWER | MRxi-xxx1 | Connect the DC 5V power supply in J10 or J12 |
| | MRxi-xxx2 | Plug the secondary of the Mains power supply adapter in J10 or J12 |
| | MRxi-xxx3 | Connect the DC 9 to 40V power supply in J10 or J12 |

Associated connector: Miniconnect MC 1,5/2-ST-3,81 from Phoenix-Contact.

| | | |
|-----------|-----------|--|
| INTERFACE | MRxi-xx1x | Connect TTL serial interface in J6 all signals must be in TTL level (0 to 5V). |
| | MRxi-xx2x | Connect RS232 serial interface in J6 all signals must be in RS232 level (-12 to +12V). |
| | Maxi-xx6x | Connect USB 2.0 interface in J11 (mini-USB B) This interface is a "Printer Class" (class 7) |
| | MRxi-xx7x | Connect Ethernet interface in J13 (RJ-45) |

Set Serial parameters with the configuration menu.
 No parameters are necessary for the USB interface.

5 CONFIGURATION MENU

Two different ways are available to configure the printer:

- by the interface (see command esc])
- by a printed configuration menu.

Here is described the printed configuration menu.

All the navigation in the Menu is made thanks to the LF push button.

Long push on the button is written <<LF>> and short push is written >LF<.

To indicate several short pushes, >LF< is followed by the quantity: >LF x2<

Activation: To activate the Configuration Menu, shortly press 4 times the Paper Feed button (>LF x2<). A 'MENU ACTIVATED' message is then printed and the first group of configuration items are printed too..

Navigation: In order to modify the settings the following steps have to be followed:

- navigate through the groups (1)
- navigate through the different items of the group (2)
- modify the value of the items (3)

Timeout: To avoid lock of the printer in the configuration Menu, if no actions are made on the LF push-button during 15 seconds, the Menu is aborted. All changes are lost and a 'MENU TIMEOUT' message is then printed. The printer can accept new data from the interface...

(1) Navigate through the groups:

- <<LF>> A long push on the LF button enters in the different items of the selected group (2).
First item is then printed...
- >LF x1< One short push on the LF button displays the next group.
New group is then printed...
- >LF x2< Two short pushes on the LF button display the previous group. New group is then printed...
- >LF x3< Three short pushes on the LF button save the modifications and exit the configuration mode.
The message 'MENU EXITED' is printed out and a reset of the printer is then performed.

(2) Navigate through the items of a group:

- <<LF>> A long push on the LF button enters in the different values of the selected item (3).
- >LF x1< One short push on the LF button displays the next item.
New item and its associated value is then printed...
- >LF x2< Two short pushes on the LF button display the previous item. New item and its associated value is then printed...
- >LF x3< Three short pushes on the LF button exit the navigation in the items and come back in the group navigation level (1).

(3) Modify the value of an item:

- <<LF>> A long push on the LF button validates the new selected parameter and prints this value in double width for control purpose. If the value is a clock item, the clock chip is immediately updated. For other items, the configuration menu **has to be exited** before the values are effective.
- >LF x1< One short push on the LF button displays the next value.
See note on the >LF x2<
- >LF x2< Two short pushes on the LF button display the previous value. **Note:** The new selected value is only printed after a certain inactive time thus allowing multiple short presses without printing. This works only for multiple pushes higher than three, because >LF x2< and >LF x3< are used for navigation purpose.
- >LF x3< Three short pushes on the LF button exit the navigation in the values and come back in the item navigation level (2).

Menu Summary Table

| Groups | Fields | Values |
|-----------|-----------------|--|
| Clock | Hours | 00 - 23 |
| | Minutes | 00 - 59 |
| | Days | 00 - 31 |
| | Months | 01 - 12 |
| | Year | 00 - 99 |
| Printer | 1: Font | Std_6x10 (Font 1), Std10x10 (Font 2) |
| | 2: Direction | TEXTMODE, DATAMODE |
| | 3: Nat. Chars | USA, FRA, GER, ENG, DK1, SWE, ITA, SPA, JAP, NOR, DK2, NDL |
| | 4: Width | Width x1, Width x2 |
| | 5: Height | Height x1, Height x2 |
| | 6: PageLength | 0..255 |
| | 7: Tab Length | |
| | 8: Gr.Hor_Res | No zoom, Zoom x1, Zoom x2 |
| | 9: Print Case | |
| | A: PCL HScale | 1..255 |
| Group #2 | B: PCL VScale | 1..255 |
| Serial | 1: Baud | 110, 150, 300, 600, 1200, 2400, 4800, 9600, 19k2 |
| | 2: Databits | 7 databits, 8 databits |
| | 3: Parity | No, Even, Odd parity |
| Group #3 | 4: Xon | Single Xon, Repeat Xon |
| Advanced | 1: Compatible | ESC/P 9pin, ESC/P Base, PCL Raw, Hexa, MRS, MP181 |
| | 2: No Paper | Fill Buff., Set Busy, Ignored, Warn Host |
| | 3: Winter/Sum | Disabled, Enabled |
| | 4: Add curve | No EXT, EXT 0, EXT 1, Both EXT |
| | 5: External | Both CPT, ADC0-CPT1, CPT0-ADC1, Both ADC |
| | 6: Info Stamp | No Stamp, Add Date, Add Logo |
| | 7: Bin. Pins | Separated, Multiplex |
| Group # 4 | 8: Bin. Init | Power Val, All Open |
| Timer | 1: Timer Use | Disabled, Enabled |
| | 2: Timer Second | 0..59 seconds |
| | 3: Timer Minute | 0..59 minutes |
| | 4: Timer Hour | 0..12 hours |
| Group #5 | 5: Alt. Print | 0..255 |

SHORT PARAMETERS EXPLANATION:

- **Set Clock:** Clock setting mode.
- **Printer:** Change printing parameters
 - Font: Default character fonts (between the 2 proposed fonts)
 - Direction: Default choice of the orientation: text or data
 - Nat. Chars. Select default national characters.
This choice is useful with 7 bits communication.
 - Width: Select default character width.
 - Height: Select default character height.
- **Serial:** Change serial parameters
 - Baud: Communication baudrate from 110 baud to 19k2 baud
 - Databits: Number of databits (7 or 8)
 - Parity: Parity kind: Even, Odd or None
 - Xon: Number of XON sended in XON / Xoff protocol before reception of the first character
 - Single XON (a single XON is transmitted)
 - Repeat XON (a XON is transmitted every 300 msecs)
 - N.B.: Hardware handshaking (RTS/CTS) is always enabled.
- **Advanced :** Change advanced parameters
 - Compatible: Interpretation of successful data e.g software compatibility ESC/P 9Pin (standard), ESC/P Base, PCL Raw, MRS ou MP181
 - Paper end: User information in case of paper defect :
 - 'Set Busy': the printer blocks the connection immediately
 - 'Fill Buff.': the buffer continues to be filled and the user will be warned when the buffer is full
 - 'Ignored': a paper defect is ignored, the printout continues
 - 'Warn Host': the user will be warned but the printout continues

Notes:

Paper defect: 'Set Busy', 'Fill Buff.' and 'Warn Host' modes warn the host by sending the character EM (19h). When the paper is present, the printer send character ETB (17h)

Head defect: Each mode warns the host by sending the character DC2 (18h), followed by the busy signal (RTS=BUSY and send of XOFF).

To correct it, check the head mechanism and push several times the linefeed button to reactivate the head. When it works again, the printer send the character (16h) and the busy condition is removed (send of XON and RTS=FREE).

When head defects occur, you must contact the repair service.

- Winter/Sum: Activation or not of the automatic change

between winter and summer time.

- **Add Curve:** Select which analogical or counting entries EXT0 and/or EXT1 will be automatically added to the graphic curves.
- **External:** Use of the entries EXT0 and EXT1
 - like analogical to digital (ADC) entries or
 - like counting entries (CPT)
- **Info Stamp:** Automatically add of information after text paragraphs
 - No Stamp: No additional information
 - Add Date: Date stamping (Date & time is added)
 - Add Logo: Logo is added (personal message)
- **Bin. Pins:** Select the management of the 4 binary entries :
 - Separated or Multiplexed.
- **Bin. Init:** Initial values of the 4 binary entries at power on :
 - "Power Val", read the initial value of each bit
 - "All Open" , initial value is 1 for each bit (open)
- **Timer :** printing timer for logo or messages #15 and #14.
 - **Timer Use :** Activate or not the timer at power on
 - **Timer Second:** Set the timer period in seconds (range 0.. 59 seconds)
 - **Timer Minute:** Set the timer period in minutes (range 0.. 59 minutes)
 - **Timer Hour:** Set the timer period in hours (range 0.. 12 hours)
Warning: if the period is set to 0, timer is disabled.
 - **Alt Print:** Cyclic ratio between printing of messages #15 and #14.
If $n > 0$, timer starts n times the printing of message #15 then only one time the printing of message #14.

6 FONTS & CONTROL CODES

6.1 CHARACTER SETS

Two complete sets of 255 IBM-II characters are available in ROM as well as national characters. Characters exist in 6x10 and 10x10 matrix with uppercase and lowercase letters.

| | | | | | | | | | | | | | | | |
|---|---|---|----|---|---|---|---|---|---|---|---|---|---|---|---|
| ! | " | # | \$ | % | & | ' | (|) | * | + | , | - | . | / | |
| 0 | 1 | 2 | 3 | 4 | 5 | 6 | 7 | 8 | 9 | : | ; | < | = | > | ? |
| @ | A | B | C | D | E | F | G | H | I | J | K | L | M | N | O |
| P | Q | R | S | T | U | V | W | X | Y | Z | [| \ |] | ^ | _ |
| ` | a | b | c | d | e | f | g | h | i | j | k | l | m | n | o |
| p | q | r | s | t | u | v | w | x | y | z | { | | } | ~ | |
| € | ü | é | ä | å | à | ç | ê | ë | è | ï | í | î | ï | À | Á |
| É | Æ | Ø | Ö | Û | Ü | Û | Ü | Û | Ü | Û | Ü | Û | Ü | Û | Ü |
| á | í | ó | ú | ñ | ñ | á | é | í | ó | ú | ñ | ñ | á | é | í |
| ⌘ | ⌘ | ⌘ | | | | | | | | | | | | | |
| L | L | T | T | - | T | T | T | T | T | T | T | T | T | T | T |
| ⌘ | ⌘ | ⌘ | ⌘ | ⌘ | ⌘ | ⌘ | ⌘ | ⌘ | ⌘ | ⌘ | ⌘ | ⌘ | ⌘ | ⌘ | ⌘ |
| α | β | γ | π | Σ | σ | μ | τ | ϕ | θ | Ω | δ | ∞ | ∅ | ε | π |
| ≡ | ± | ≥ | ≤ | ∫ | J | ÷ | ≈ | ° | · | - | √ | n | z | . | |

Font: Standard 6 x 10

| | | | | | | | | | | | | | | | |
|---|---|---|----|---|---|---|---|---|---|---|---|---|---|---|---|
| ! | " | # | \$ | % | & | ' | (|) | * | + | , | - | . | / | |
| 0 | 1 | 2 | 3 | 4 | 5 | 6 | 7 | 8 | 9 | : | ; | < | = | > | ? |
| @ | A | B | C | D | E | F | G | H | I | J | K | L | M | N | O |
| P | Q | R | S | T | U | V | W | X | Y | Z | [| \ |] | ^ | _ |
| ` | a | b | c | d | e | f | g | h | i | j | k | l | m | n | o |
| p | q | r | s | t | u | v | w | x | y | z | { | | } | ~ | |
| € | ü | é | ä | å | à | ç | ê | ë | è | ï | í | î | ï | À | Á |
| É | Æ | Ø | Ö | Û | Ü | Û | Ü | Û | Ü | Û | Ü | Û | Ü | Û | Ü |
| á | í | ó | ú | ñ | ñ | á | é | í | ó | ú | ñ | ñ | á | é | í |
| ⌘ | ⌘ | ⌘ | | | | | | | | | | | | | |
| L | L | T | T | - | T | T | T | T | T | T | T | T | T | T | T |
| ⌘ | ⌘ | ⌘ | ⌘ | ⌘ | ⌘ | ⌘ | ⌘ | ⌘ | ⌘ | ⌘ | ⌘ | ⌘ | ⌘ | ⌘ | ⌘ |
| α | β | γ | π | Σ | σ | μ | τ | ϕ | θ | Ω | δ | ∞ | ∅ | ε | π |
| ≡ | ± | ≥ | ≤ | ∫ | J | ÷ | ≈ | ° | · | - | √ | n | z | . | |

Font: Standard 10 x 10

The selection of national characters is done by software or by the configuration menu.

6.2 CONTROL CODES PCL RAW

The compatibility PCL Raw has been implemented in order to allow the printer to work with computers. Only the graphic functions are implemented. The other control codes are ignored. The compression algorithms Run Length and Tiff are supported. Delta Row will be available as soon as possible.

| Mnemonics | Hex | PCL codes available |
|---------------|-------|--|
| ESC "&" | 1B 26 | |
| ESC "&" a # H | | Horizontal position |
| ESC "*" | 1B 2A | |
| ESC "*" b # W | | Graphics printing |
| ESC "*" b # M | | Selection of compression algorithm : without compression, Run Length, Tiff, Delta Row |
| ESC "*" r # T | | Page length |
| ESC "*" p # X | | Page width |
| ESC "E" | 1B 45 | Soft reset |

6.3 CONTROL CODES ESC/P 9 PINS

The compatibility ESC/P 9 PINS has been implemented in order to allow the printer to works with computers. Only the graphic functions are implemented. The other control codes are ignored. The codes implemented are shown with a mark in the column '9 Pin' of the table.

6.4 CONTROL CODE ESC/P BASIC

These codes are less compatible with ESC/P, but they give some functions more specific to the printer. Most of these codes work same way as 9 pins.

Attention, Major difference in graphic:

The graphic modes are very similar, but the function of the CR at the end of the graphic is different :

- for ESC/P Basic, the code CR makes a line feed like a LF code.
- for ESC/P 9 pins, the code CR makes only a carriage return without any line feed.

The characters with their ASCII values between 01 hex and 1F hex are control characters and are not printable. These characters allow to modify the behaviour of the interface (control characters).

| Mnemo | Hex | Control codes | Basic | 9 Pins |
|----------|-------|--|-------|--------|
| HT | 09 | Tabulation | x | x |
| LF | 0A | Line feed | x | x |
| FF | 0C | Page feed | x | x |
| CR | 0D | Carriage return | x | x |
| SO | 0E | Double width | x | x |
| DC4 | 14 | Normal width | x | x |
| ESC "!" | 1B 21 | Master mode | | x |
| ESC "\$" | 1B 24 | Horizontal position: nL nH | | x |
| ESC "" | 1B 27 | Graphic Printing | x | |
| ESC ")" | 1B 29 | Advance of n lines of characters | x | x |
| ESC "*" | 1B 2A | Graphic Printing : 8 points per column (ESC "*" 0, ESC "*" 1, ESC "*" 2 or ESC "*" 3) | x | x |
| ESC "-" | 1B 2D | Underscore ON:OFF | x | x |
| ESC "2" | 1B 32 | Sets interlining to 0 | x | x |
| ESC "3" | 1B 33 | Sets interlining to n | x | x |
| ESC "@" | 1B 40 | Soft reset | x | x |
| ESC "C" | 1B 43 | Page length | x | x |
| ESC "D" | 1B 44 | Sets tabulations | x | x |
| ESC "F" | 1B 46 | Font selection | x | |
| ESC "J" | 1B 4A | Advance of n lines of dots | x | x |
| ESC "K" | 1B 4B | Graphic Printing : 8 dots/columns | x | x |
| ESC "L" | 1B 4C | Graphic Printing : 8 dots/columns | x | x |
| ESC "M" | 1B 4D | Selection of the font 1 (6x10) | | x |
| ESC "P" | 1B 50 | Selection of the font 2 (10x10) | | x |

| Mnemo | Hex | Control codes | Basic | 9 Pins |
|---------|-------|---|-------|--------|
| ESC "R" | 1B 52 | Selection of national characters | x | x |
| ESC "S" | 1B 53 | Control of status DEL | x | |
| ESC "V" | 1B 56 | Synchronisation character (RS232 only) | x | |
| ESC "W" | 1B 57 | Character widening | x | x |
| ESC "Y" | 1B 59 | Graphic Printing : 8 dots/columns | x | x |
| ESC "Z" | 1B 5A | Graphic Printing : 8 dots/columns | x | x |
| ESC "a" | 1B 61 | Selection of the alignment | x | x |
| ESC "c" | 1B 63 | Date stamping & clock setting | x | |
| ESC "f" | 1B 66 | Printing of 1 line of dots | x | |
| ESC "g" | 1B 67 | Selection of the font 1 (6x10) | | x |
| ESC "j" | 1B 6A | Prints but do not go back | | x |
| ESC "t" | 1B 74 | Selection of the table of the characters codes | | x |
| ESC "x" | 1B 78 | Selects the printing NLQ or Draft | | x |
| ESC "w" | 1B 77 | Elongation of the characters | x | x |
| ESC "r" | 1B 7B | Selection of the direction of the printout : Text or Data | x | x |
| GS "V" | 1D 56 | Advances to the cutting bar, then n/2 lines of dots | x | |
| GS "I" | 1D 5B | Switch acquisition (RS232 only) | x | |
| GS "I" | 1D 5E | Configuration of the switches | x | |
| GS "A" | 1D 5E | Activation of the timer | x | |
| GS "c" | 1D 63 | Date stamping & clock setting | x | |
| GS "m" | 1D 6D | Printing of a pre-stored message | x | |
| GS "p" | 1D 70 | Printing of the logo | x | |
| GS "s" | 1D 73 | Programmation of the messages & logo | x | |
| GS "u" | 1D 75 | Transmission of data trough the serial. (RS232 only) | x | |
| GS "v" | 1D 76 | Return of data towards the emitter. (RS232 only) | x | |

6.5 CONTROL CODE MRS & MP-181

The compatibility MRS and MP-181 has been implemented in order to allow direct replacement of the older printers: MRS ans MP-181.

| Mnemo | Hex | Control codes |
|-------|-----|------------------------|
| SOH | 01 | ASCII character set |
| STX | 02 | Graphic bar |
| EOT | 04 | French character set |
| ACK | 06 | Graphic bar pattern |
| BEL | 07 | Clock (set or display) |
| TAB | 09 | Tabulation |
| LF | 0A | Line feed |
| FF | 0C | White line |
| CR | 0D | Carriage return |

| Mnemo | Hex | Control codes |
|-------|-----|--------------------|
| SO | 0E | Double width |
| SI | 0F | Text mode |
| DLE | 10 | Data mode |
| DC3 | 13 | Special characters |
| DC4 | 14 | Single width |
| SYN | 16 | Black line |
| ETB | 17 | Feed n lines |
| SUB | 1B | Cut paper |
| ESC | 1B | Register mode |

7 ANNEXE

7.1 CABLES AND CONSUMABLES

| Part number | Description |
|----------------|--|
| DKM-242-V | Serial cable RS232C/V24 <ul style="list-style-type: none">• HE10-2x5 pins / Sub-D9-F• Length mini 1m50 |
| MPA-NO-58-50-1 | White Paper Roll <ul style="list-style-type: none">• Width 58 mm \pm 0,5 mm• External diameter 50 mm• Length 20 m \pm 10% |
| MPA-NO-58-50-2 | Duplicating White Paper Roll <ul style="list-style-type: none">• 2 sheetsWidth 58 mm \pm 0,5 mm• External diameter 50 mm• Length 17 m \pm 10% |
| MPA-SP-58-46-1 | Self-revelant White Paper Roll (micro-bubbled) (ink cartridge unnecessary) <ul style="list-style-type: none">• Width 58 mm \pm 0,5 mm• External diameter 46 mm• Length 17 m \pm 10% |
| MDE-250-N | Black Ink cartridge <ul style="list-style-type: none">• Life length about 100 000 characters |
| MDE-250-V | Purple Ink cartridge <ul style="list-style-type: none">• Life length about 100 000 characters |



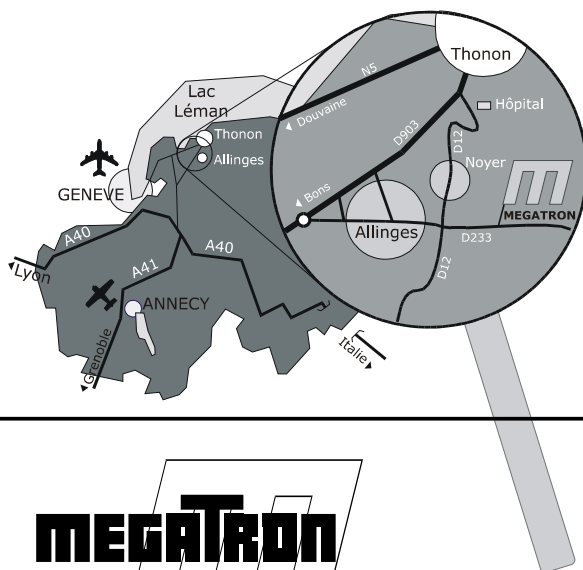

Potentiomètres de précision

Résistances de précision

Servo-Systèmes

Capteurs

Interfaçage

Systèmes d'impression

Claviers

Techniques d'affichage

Centre de production

et Bureaux Commerciaux

MEGATRON

Z.I. de Noyer

B.P. 1

F- 74200 ALLINGES

Tél: +33 (0) 4.50.70.54.54 - Fax: +33 (0) 4.50.70.56.56

Internet: <http://www.megatron.fr> - E-mail: info@megatron.fr