



TP UP-PN

Portable Dot Matrix Printer

User's Manual

The contents of this manual are subject to change without notice .

Contents

Brief introduction	2	3.3 Formatting Commands	15
Chapter 1 Features	3	3.4 Character Setting Commands	21
1.1 Printing Features	3	3.5 User-Defined Character Commands	26
1.2 Print Paper	3	3.6 Printing Graphics Commands	28
1.3 Ribbon	3	3.7 Initialization Command	31
1.4 Character	3	3.8 Data Control Commands	31
1.5 Printing Control Commands	4	3.9 Hexadecimal Dumping Command	32
1.6 Interface	4	3.10 Chinese Character Printing Commands	32
1.7 Power Supply	4	3.11 Black Mark Detecting Command	33
1.8 Power On and Off Automatically	5	Chapter 4 Battery Charge and Discharge	36
1.9 Black Mark Detecting	5	4.1 Battery	36
1.10 Operation Environment	5	4.2 Charging Method	36
1.11 Overall dimension	5	4.3 Discharging Method	36
1.12 Weight	5	4.4 Method of getting back the capacity	37
Chapter 2 Installation and Operation	6	Chapter 5 Notice about the IrDA Infrared Interface	38
2.1 Installation	6	Chapter 6 Notice about the Rechargeable Ni-MH Battery	39
2.2 Power Connection	6	6.1 Ni-MH Rechargeable Battery characteristics	39
2.3 Loading Paper	7	6.2 Notice:	40
2.4 Replacing the ribbon cassette	8	Appendix 1 Specifications	42
2.5 Interface Selecting	9	Appendix 2 Printing Control Commands	43
2.6 Interface connection	9	Appendix 3 Character Code Tables	45
2.7 Operation of Indicators and Buttons	11		
Chapter 3 Printing Control Commands	13		
3.1 Summary	13		
3.2 Paper Feeding Commands	13		

Brief introduction

TP UP-PN portable eight dot matrix printer features as following:

- Structure for easy paper loading
- Rechargeable battery pack for quick replacing and portability
- IrDA infrared interface for easy interfacing and communication wireless
- Built-in Chinese font level 1 & 2 for quick and nice printing Chinese characters
- Black mark sensor for implement of printing pre-printed bill on position
- It has copy ability; it can provide an original and a copy.

TP UP-PN portable 8 dot matrix printer is suitable for application of mobile instrument or such as PDA、 POS etc device.

Chapter 1 Features

1.1 Printing Features

- Printing method: Dot matrix printing
- Copy ability: 1(original) +1
- Model: TP UP-PN support EPSON M-190 series printer head. The main models are shown in the follow table

Model	Character per line (5×7)	Character dimension (mm)	Print speed (line/s)	Fast feeding paper speed	Print density (dot/line)	Reliability (MCBF)
TP UP-PN24S	24	1.7×2.6	2.1	5.0	144	1500thous and lines
TP UP-PN40S	40	1.1×2.6	1.5	3.0	240	1000 thousand lines

1.2 Print Paper

- Normal paper roll, max OD: 50mm, ID: 12.5mm
- Paper width: 57.5 ± 0.5mm
- Paper thickness: 0.065 μ m, 53~64g/m²

1.3 Ribbon

- ERC-09: cassette, purple, life: 250 thousand characters.
- ERC-22: cassette, purple, life: 1000 thousand characters.

1.4 Character

- ANK Characters: 96 ASCII and 352 other characters: Greek, Germany, Russian, France, Japanese Katakana, Chinese(5 × 7 dot matrix) and 32 user definable characters.

Mathematical symbol, Printing mark, Block graphics.

Standard character fonts are 5 × 7 dot matrix. All others are 6 × 8 dot matrix.

- Chinese: GB level 1 and level 2 Chinese 15 × 16 dot matrix

1.5 Printing Control Commands

The UP-PN provide 42 commands include ESC/POS commands、FS Chinese print control commands、 and GS Black Mark control commands.

- Character dot graphics printing commands

ESC/P provide the functions as:

Enable printing characters and dot graphics、 enlarge characters、 underline characters、 user-defined characters printing、 formatting、 hexadecimal dumping.

- Chinese characters printing commands

FS commands support the GB level 1 and level 2 Chinese font、 Roman、 and tabs. Refer to the chapter 3 printing control commands.

- GS FF Black Mark detecting command

Detect the Black Mark and feed paper to the beginning of next paper.

1.6 Interface

TP UP-PN provides both interfaces of RS-232 serial port and IrDA infrared port.

- RS-232 Serial port

Baud rate: 9600bps

Handshaking: RTS/CTS

Data format: 8-bit data, none parity, 1-bit stop

Connector: 6 pin RJ-11 modular jack

Signal level: EIA level $\pm 3 \sim \pm 15V$

- IrDA infrared port

Communication distance: 1m(max.)

Communication angle: 30

1.7 Power Supply

- DC 6V 1500mAh rechargeable battery pack.
- Battery slowly charging on printer with external DC9 ~ 12V/300mA adaptor
- Battery fast charging on CX-101 quick charger (option)

1.8 Power On and Off Automatically

- Press button “ On” for printer power on
- Power off automatically for 60 seconds no operations or press and keep the button ON for 5 seconds.

1.9 Black Mark Detecting

- Black mark should be printed on printing side close edge left with a height 5mm and width 15mm ;
- Reflectivity of black mark should be less than 10% and the others should be more than 75%.

1.10 Operation Environment

- Temperature: 0~50
- Humidity: 10~80%RH

1.11 Overall dimension

- 153(L) × 116(W) × 65(H)mm

1.12 Weight

- 530g(excluding paper roll)

Chapter 2 Installation and Operation

2.1 Installation

TP UP-PN portable dot matrix printer has an outline as shown figure 2-1:

Battery installation: put the battery into the battery house in the bottom of the printer. Please notice the polarity of the battery fitting to the electrode in the battery house. When heard a sound of “peng” the battery has installed and locked into the house. For taking out the battery push the release bar (see figure 2-2) to the battery.

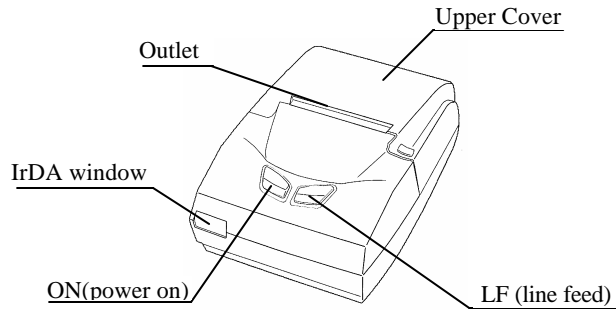

Figure 2-1 TP UP-PN outline

2.2 Power Connection

A rechargeable battery is packed with TP UP-PN printer. It can be installed and locked on the bottom of the printer. DC12V/600mA adaptor pack is used to slow charging. When the plug of the adaptor is inserted into the DC jack on the bottom of the printer, trickle charging started. Full charging needs 14 hours. Fast charging need take off the battery and put it on the optional quick charger CX-101 (option). Full charging needs only 4 hours. For the first use of the printer, we recommend you charge the battery fully before you use the printer.

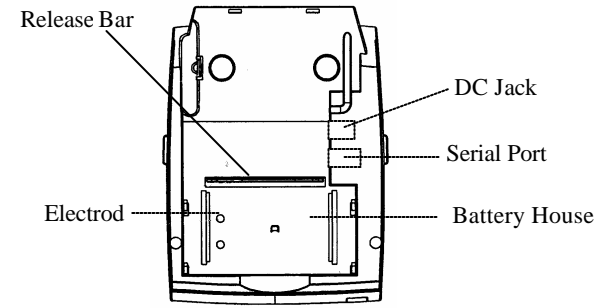

Figure 2-2 Battery installation

2.3 Loading Paper

The step of loading paper is as follows:

1 Open the removable cover of printer as Figure 2-3(a, b).

2 Insert the paper roll into the paper house shown as figure, the core of the roll should be put on the paper holder. Press and keep the FL button for feeding paper. Wait a moment for a little bit of paper into the paper entry slot. Then release the FL button or switch off the power to stop paper feed (see figure 2-3 c).

3 Let the paper come on from the paper exit on the top of printing mechanism. Close the cover and let paper edge locate outside (see figure 2-3 d).



(a)



(b)

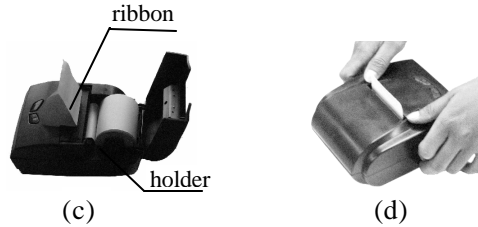

Figure 2-3 Loading paper

2.4 Replacing the ribbon cassette

TP UP-PN printers have a ribbon cassette loaded at ex-factory but cassette needs to replace since it has been used for a period of time. If you prepare to replace the cassette, you can do as the following steps:

- 1 Open the upper cover of the printer
- 2 Push the button mark with “push” (refer to figure 2-4) and take out the cassette
- 3 Insert a new cassette.

Put the left end slightly on the axle of the gear that is on the left side of printer mechanism. Mean while, keep the right end little higher than the left. If find the left end has not fallen to the axle completely, please press the knob of the cassette and make it slowly turned clockwise as shown by the arrow. You can press down the right end of the cassette only after lay the left end down to the axle deep enough. Now check the ribbon if or not it is tight and keeps on the inside of the cassette. Turn the knob clockwise again when find the ribbon on the outside of the cassette.

- 4 Finally close the cover of the printer.

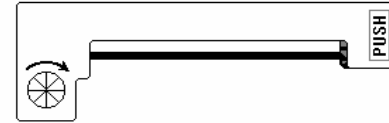

Figure 2-4 Ribbon

2.5 Interface Selecting

TP UP-PN printer allows to select using RS-232 serial interface or IrDA infrared interface.

- 1). RS-232 serial interface:

Connect the RS-232 serial interface cable specified with the printer, the printer will set to use RS-232 serial interface.

- 2). IrDA infrared interface:

If there is no RS-232 serial interface cable connected with the printer, the printer will set to use IrDA infrared interface.

2.6 Interface connection

2.6.1 Serial Interface Connection

TP UP-PN portable printer provides a RS-232 serial port socket: 6PIN RJ-11 modular jack.

- 1) RJ-11 Pin Alignment

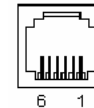

Figure 2-5 RJ-11 Pin Alignment

2) Serial Port Signal Definition

Pin	Signal	Source	Description
1	GND	Printer	Signal ground
2	RXD	Host	Printer receiving data sent by host
3	TXD	Printer	Printer send data to host
4	GND	Printer	Signal ground
5	RTS	Printer	“Mark” indicates printer is busy and can’t receive data; “ Space” indicates printer is ready to receive data.
6	CON	Printer	Connect with Pin1, set to RS-232C serial interface mode

Mark=logic “ 1 ” (EIA level -3V~-15V)

Space=logic “ 0 ” (EIA level +3V~+15V)

3) Connecting with Personal Computer

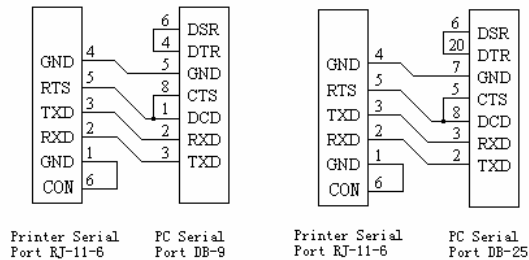

Figure 2-6 Connecting with PC

4) Communication Parameters:

Baud rate: 9600bps

Handshaking: RTS/CTS

Data Bit: 8

Parity: none

Stop bit: 1

2.6.2 IrDA Infrared Interface:

IrDA works in semiduplex mode wireless. To communicate the IrDA infrared transmitter and receiver of the host should aim at the infrared window of the printer.

Communication parameters are following as:

Baud rate: 9600bps

Data bit: 8

Parity: none

Handshaking: none

Distance: 1m(max.)

View angle: 30 °

2.7 Operation of Indicators and Buttons

TP UP-PN has two indicators: the left one is a dichromatic light, red light indicate charging the battery green light indicate printer under working, the right one is a error indicator, and lights or flash when error occurs.

The power indicator turn green when turn on the printer.

The status indicator flashes when paper run out or Black Mark Detect failure. Error indicator flashes as shown as figure 2-7(high level indicate the light lights).

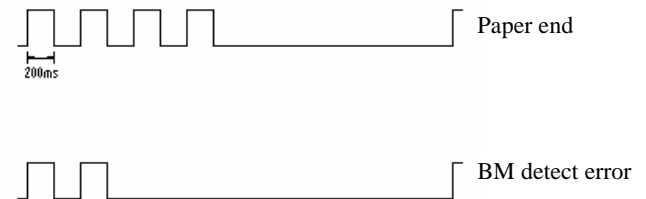

Figure 2-7 Error indicator flash mode

TP UP-PH has two buttons shown as figure 28: ON and LF. Their functions are following:

Chapter 3 Printing Control Commands

- (1) Power on: press button ON and release it until green indicator lights. That means power is ON;
- (2) Power off: Power off automatically for 60 seconds no operations. Press button ON and keep more than 5 seconds, then release the button, the printer will power off.
- (3) Self Test: when power off, press and hold button LF, and then press button ON, both indicators light, then release button LF and button ON, printer will print out self-test list;
- (4) Paper feed: when power on, press button LF and paper feed until release the button;
- (5) Battery discharging: when power off, press button ON more than 10 seconds, both indicators light, printer enters battery discharging status, and no normal operations can be made. When the battery discharged to empty, printer power off automatically.

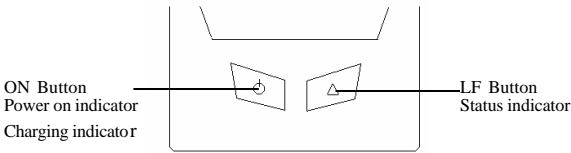

Figure 2-8 Indicators and Buttons

3.1 Summary

TP UP-PN portable thermal printer provides a set of print control commands includes: byte control commands, ESC control commands, FS control commands, GS control commands. The commands provide the functions described as following:

- (1) Defining the format
- (2) Enlarge character printing
- (3) Printing dot matrix graphics
- (4) Selecting character set
- (5) User-defined characters
- (6) Printing Chinese
- (7) Others

The format of each printing commands is illustrated below:

Printing Command	Function
Format: ASCII :	the sequence in standard ASCII characters
Decimal :	the sequence in decimal numbers
Hexadecimal :	the sequence in hexadecimal numbers

Explanation: description of the command.

Example: Some examples are listed to illustrate the command for better understanding.

3.2 Paper Feeding Commands

LF	Print and Line Feed
Format: ASCII :	LF
Decimal :	10
Hexadecimal :	0A

Explanation:

Print data of current line in buffer and feed one line. Only feed one line if data buffer is empty.

ESC J Perform 'n' dot-line feed

Format:	ASCII	:	ESC J	n
	Decimal	:	27 74	n
	Hexadecimal	:	1B 4A	n

Explanation:

Print the data of buffer if it exists.

Line feed n dot-lines forward. The value of n is 1 ~ 255.

Note: the line spacing may be changed after use enlarging character command ESC V or ESC W.

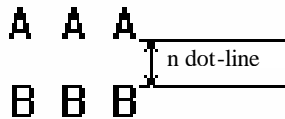

ESC I Set 'n' dot-line spacing

Format:	ASCII	:	ESC I	n
	Decimal	:	27 49	n
	Hexadecimal	:	1B 31	n

Explanation:

Set n dot-line spacing for future Line Feed command.

The value of n ranges 0~ 255. Usually set n=0 before using ESC K command to print bit-map graphics. Normally set n=3 at text printing mode. Default value is n=3.

Example:

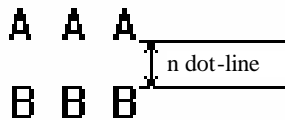

Observe the effect of the command by following BASIC program:

```

10 FOR I=1 TO 10 STEP 2
20 PRINT #1, CHR$(27);"I";CHR$(I);          'ESC I, set line spacing.
30 PRINT #1, "LINE SPACING";CHR$(10);      'Print string and Carriage
      Return.
40 NEXT I
  
```

A printout of above program on TP UP-PN is below:

```

LINE SPACING
LINE SPACING
LINE SPACING
LINE SPACING
LINE SPACING
  
```

FF Form Feed

Format:	ASCII	:	FF
	Decimal	:	12
	Hexadecimal	:	0C

Explanation:

Feed paper to the beginning side of next page.

3.3 Formatting Commands

ESC C Set page length

Format:	ASCII	:	ESC C	n
	Decimal	:	27 67	n
	Hexadecimal	:	1B 43	n

Explanation:

Set page length with n character lines. The value of n should be in 0 - 255.

The page length will be defined as 256 lines if n=0.

The default value is n=40.

ESC N Set bottom margin

Format:	ASCII	:	ESC N	n
	Decimal	:	27 78	n
	Hexadecimal	:	1B 4E	n

Explanation:

Set bottom margin into n lines. The value of n should be in 0 - 255. The default value is n=0.

The bottom margin means the numbers of space line from the last printable line on one page to the end of the page.

For instance, if set bottom margin is 3 lines then issue the following code sequence:

ASCII	:	ESC N	ETX
Decimal	:	27 78	3
Hexadecimal	:	1B 4E	03

The BASIC program sending above code sequence is below:

```
PRINT #1, CHR$(27);"N";CHR$(3);
```

ESC O Cancel bottom margin

Format:	ASCII	:	ESC O
	Decimal	:	27 79
	Hexadecimal	:	1B 4F

Explanation:

Set bottom margin to 0 line. It means that printer will prints one by one line without space lines between two continual pages.

ESC B Set vertical tabs

Format:	ASCII	:	ESC B	n1	n2	n3	...	NUL
	Decimal	:	27 66	n1	n2	n3	...	0
	Hexadecimal	:	1B 42	n1	n2	n3	...	00

Explanation:

The vertical tab position is defined as n1, n2 and etc. All its values must be limited to the range of page length set by ESC C command.

The character NUL added at last indicates the end of the command.

All the vertical tab position can be canceled by ESC B NUL command.

VT command executes the vertical tab and feed paper to the position of

next vertical tab.

For example: set three positions of vertical tab separately in line 2,5 and 8.

You can send following command.

ASCII	:	ESC B	STX	ENQ	BS	NUL
Decimal	:	27 66	2	5	8	0
Hexadecimal	:	1B 42	02	05	08	00

Its BASIC program is:

```
10 PRINT #1, CHR$(27);"B";CHR$(2);CHR$(5);CHR$(8);CHR$(0);ESC B
    command
20 PRINT #1, CHR$(11); 'VT command
30 PRINT #1, "VTAB1"; 'Print string
40 PRINT #1, CHR$(11); 'VT command
50 PRINT #1, "VTAB2"; 'Print string
60 PRINT #1, CHR$(11); 'VT command
70 PRINT #1, "VTAB3"; 'print string
```

The printout running this program in TP UP-PN is as follows:

```
VTAB1
VTAB2
VTAB3
```

VT Vertical tab

Format:	ASCII	:	VT
	Decimal	:	11
	Hexadecimal	:	0B

Explanation:

Feed paper to the position of the next vertical tab set by ESC B.

Note: if no vertical tab setting before or the current position equals or exceeds the last position of vertical tab, VT command only feeds paper one line (same as LF command).

ESC D		Set horizontal tabs							
Format:	ASCII	:	ESC D	n1	n2	n3	...	NUL	
	Decimal	:	27	68	n1	n2	n3	...	0
	Hexadecimal	:	1B	44	n1	n2	n3	...	00

Explanation:

The horizontal tab position is defined as n1, n2 and etc. All its values must be limited to the range of printing width based on the model of printer (Seeing at Section 1.1).

The character NUL added at last indicates the end of this command.

All the setting base on ESC D can be cancel by the form ESC D of this command.

HT command executes the horizontal tab.

For example: set three positions of horizontal tab separately in column 2, 9 and 14. You can send following command.

```

ASCII : ESC D STS HT SO NUL
Decimal : 27 68 2 9 14 0
Hexadecimal : 1B 44 02 09 0E 00

```

Its BASIC program is:

```

10 PRINT #1, "1234567890123456"          'Scalar
20 PRINT #1, CHR$(27);"D";CHR$(2);CHR$(9);CHR$(14);CHR$(0); 'ESC
   D command
30 PRINT #1, CHR$(9);                    'HT command
40 PRINT #1, "HT1";                       'Print string
50 PRINT #1, CHR$(9);                    'HT command
60 PRINT #1, "HT2";                       'Print string
70 PRINT #1, CHR$(9);                    'HT command
80 PRINT #1, "HT3";                       'Print string

```

The printout of running this program in TP UP-PN is as follows:

```

1234567890123456
HT1  HT2  HT3

```

HT		Horizontal tab	
Format:	ASCII	:	HT
	Decimal	:	9
	Hexadecimal	:	09

Explanation:

Printing continues to the position of next horizontal tab set by ESC D.

If no horizontal tab setting before or if the current position equals or exceeds the last position of horizontal tab. HT command will be no action.

ESC f		Print blank character or lines			
Format:	ASCII	:	ESC f	m	n
	Decimal	:	27	102	m n
	Hexadecimal	:	1B	66	m n

Explanation:

If m=0, ESC f NUL n command prints n blank characters. The value of n should be in the range of printing width specified by the model of printer. (Seeing at Section 1.1).

If m=1, ESC f SOH n command prints n blank lines. The value of n should range among 0 and 255.

For instance: Print 6 blank characters in one line, you can send following command:

```

ASCII : ESC f NUL ACK
Decimal : 27 102 0 6
Hexadecimal : 1B 66 00 06

```

Another instance is printing 6 blank lines. You can send the follows:

```

ASCII : ESC f SOH ACK
Decimal : 27 102 1 6
Hexadecimal : 1B 66 01 06

```

ESC Q		Set right margin	
Format:	ASCII	:	ESC Q n
	Decimal	:	27 81 n
	Hexadecimal	:	1B 51 n

Explanation:

The value of n should be in 0 to the range of printing width specified by

the model of printer. (Seeing at Section 1.1).

The default value is n=0, that is, no right margin.

The position is absolutely set by this command, so it is not affected by ESC U and ESC W character enlarge commands.

If reach to the right margin set by the command, printer would add Carriage Return and Line Feed automatically.

For example, to set right margin into 24, you can send following command

```
ASCII   :   ESC Q   ACK
Decimal :   27   81   6
Hexadecimal :   1B   51   06
```

The BASIC program for the above example is shown as follows:

```
10 PRINT #1, "123456789012345678901234"
20 PRINT #1, CHR$(27);"Q";CHR$(6); 'ESC Q command
30 PRINT #1, "1234567890123456789012345678901234567890"
```

The printout of running the program in TP UP-PN printer is shown below:

```
123456789012345678901234
123456789012345678
901234567890123456
7890
```

ESC I	Set left margin
Format: ASCII	: ESC I n
Decimal	: 27 108 n
Hexadecimal	: 1B 6C n

Explanation:

The value of n should be in 0 to the range of printing width specified by the model of printer.

The default value is n=0, that is, no left margin.

The position is absolutely set by this command, so it is not affected by ESC U and ESC W character enlarge commands.

For instance, to set left margin into 6, you can send following command:

```
ASCII   :   ESC I   ACK
Decimal :   27   108   6
Hexadecimal :   1B   6C   06
```

The BASIC program for the above example is shown below:

```
10 PRINT #1, "123456789012345678901234" 'Scalar
20 PRINT #1, CHR$(27);"I";CHR$(6); 'ESC I command
30 PRINT #1, "1234567890123456789012345678901234567890"
```

The printout of running the program in TP UP-PN printer is shown below:

```
123456789012345678901234
123456789012345678
901234567890123456
7890
```

3.4 Character Setting Commands

ESC U	Enlarge width
Format: ASCII	: ESC U n
Decimal	: 27 85 n
Hexadecimal	: 1B 55 n

Explanation:

The width of character or graphics will be n times wider than normal one. The value of n should range in 1 - 4. The default value is n=1, that is, normal width without enlarging.

For observing the enlarging effect of ESC U command, please run following BASIC program:

```
10 FOR I=1 TO 3 'From 1 to 3 times
20 PRINT #1, CHR$(27);"U";CHR$(I); 'ESC U command
30 PRINT #1, "TP"; 'Print string
40 NEXT I
50 PRINT #1, CHR$(13); 'CR command
```

The printout of running the program in TP UP-PN printer is shown below:

TPTPTP

Note: This command is active just after issuing ESC W SOH (n=1) command.

ESC V Enlarge height

Format:	ASCII	:	ESC V	n
	Decimal	:	27 86	n
	Hexadecimal	:	1B 56	n

Explanation:

The height of character or graphics will be n times higher than normal one. The value of n should range in 1 - 4. The default value is n=1, that is, normal height without enlarging.

This command should issue at the beginning of printer operation.

For observing the enlarging effect, please use following BASIC program:

```
10 FOR I=1 TO 3      'From 1 to 3 times
20 PRINT #1, CHR$(27);"V";CHR$(I); 'ESC V command
30 PRINT #1, "TP"    'Print string
40 NEXT I
```

The printout of running the program in TP UP-PN printer is shown below:

TP
TP
TP

Note: This command is active just after issuing ESC W SOH (n=1) command.

ESC W Enlarge width & height

Format:	ASCII	:	ESC W	n
	Decimal	:	27 87	n
	Hexadecimal	:	1B 57	n

Explanation:

The printing width and height will be n times bigger than normal one. The value of n should range among 1 to 4. The default value is n=1, that is, normal width and height without enlarging.

For observing the enlarging effect of ESC W command, please run following BASIC program:

```
10 FOR I=1 TO 3      'From 1 to 3 times
20 LPRINT CHR$(27);"W";CHR$(I); 'ESC W command
30 PRINT "TP"       'Print string
40 NEXT I
```

The printout of running the program in TP UP-PN printer is shown below:

TP

TP

TP

ESC - Turn underline on/off

Format:	ASCII	:	ESC -	n
	Decimal	:	27 45	n
	Hexadecimal	:	1B 2D	n

Explanation:

Underline is turned on if n=1 and turned off if n=0.

All characters including blank ones are underscored except meet the command of turning off underline.

The BASIC program for observing the effect of ESC - command is shown below:

```
20 PRINT #1, "TP";
30 PRINT #1, CHR$(27);"-";CHR$(1); 'Turn underline on
```

```
40 PRINT #1, "UPT";      'UPSF prints underline
50 PRINT #1, CHR$(27);"-";CHR$(0); 'Turn underline off
60 PRINT #1, "TP"
```

The printout of running the program in TP UP-PN printer is shown below:

TPUPTTP

ESC 6	Select Font 1
Format: ASCII :	ESC 6
Decimal :	27 54
Hexadecimal :	1B 36

Explanation:

All characters in use will be from Font 1 after issuing this command.

There are two sets of fonts available in TP UP-PN printers. Font 1 is selected when power on or ESC @ command is active.

ESC 7	Select Font 2
Format: ASCII :	ESC 7
Decimal :	27 55
Hexadecimal :	1B 37

Explanation:

All characters in use will come from Font 2 after issuing this command.

Refer to command ESC 6.

SO	Select double-width printing
Format: ASCII :	SO
Decimal :	14
Hexadecimal :	0E

Explanation:

All characters will be printed with double-width as normal one in the current line after issuing the command. Carriage Return or DC4 commands can terminate SO command.

However normal and width-enlarging characters can be mixed in the same line.

DC4	Cancel double-width printing
Format: ASCII :	DC4
Decimal :	20
Hexadecimal :	14

Explanation:

Cancel the double-width printing in one line selected by SO command.

This command does not cancel enlarging mode selected by ESC U and ESC W commands.

ESC i	Turn reverse printing on/off
Format: ASCII :	ESC i n
Decimal :	27 105 n
Hexadecimal :	1B 69 n

Explanation:

If n=1, then turn on the reverse printing. If n=0 turn off it. Reverse printing is white on black, as in a photographic negative.

Normal printing is black in white. It is selected when power on or issue ESC @ command.

The BASIC program for reverse printing is as follows:

```
10 PRINT #1, CHR$(27);"i";CHR$(1); 'Turn reverse printing on
20 PRINT #1, " ABCDEFGHIJKLMNOP"
```

The printout of running the program in TP UP-PN printer is shown below:

A B C D E F G H I J K L M N O

ESC c	Turn inverse printing on/off
Format: ASCII :	ESC c n
Decimal :	27 99 n
Hexadecimal :	1B 63 n

Explanation:

If n=1, then turn inverse printing on. If n=0, turn it off. Reverse printing is usual in wall-mounted printer, so that the printout is easy to read. The default is n=0.

3.5 User-Defined Character Commands

ESC &	Define user-defined character							
Format:	ASCII	:	ESC &	m	n1	n2	...	n6
	Decimal	:	27 38	m	n1	n2	...	n6
	Hexadecimal	:	1B 26	m	n1	n2	...	n6

Explanation:

The command allows user to define a user-defined character. The parameter m is the code of this character. The value of the code ranges among 32 and 255.

Parameter n1, n2, ..., n6 are the structure code of the character. The character is composed of 6X8 dot matrix, that is, 6 dot-columns by 8 dot-lines. One byte of the data corresponds to one column of the character. The MSB of the byte is at top of the column. Refer to following structure:

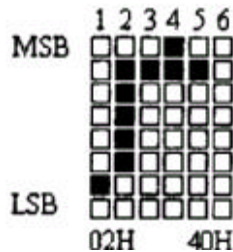

User-defined characters are stored in RAM but they will be lost when power off.

If several ESC & commands used the identical value of the m only the last m would be available. The number of the user-defined character is able up to 32. Please refer to ESC % and ESC : commands.

ESC %	Replace with user-defined character								
Format:	ASCII	:	ESC %	m1	n1	m2	n2...mk	nk	NUL
	Decimal	:	27 37	m1	n1	m2	n2...mk	nk	0
	Hexadecimal	:	1B 25	m1	n1	m2	n2...mk	nk	00

Explanation:

This command can replace the character n of current fonts with user-defined character m. the user-defined character m will be printed after issuing the command, which is substitute for the character n in current fonts.

m1, m2..mk are codes of user-defined character.

n1, n2..nk are codes of characters in current fonts and will be replaced.

Value for both m and n ranges among 32 and 255.

The value of subscript ? ranges among 1 and 32. The maximum number of characters that can be replaced is 32.

The character NUL adds in the last to indicate the end of the command.

Please refer to ESC & and ESC : commands.

ESC :	Restore the font character		
Format:	ASCII	:	ESC :
	Decimal	:	27 58
	Hexadecimal	:	1B 3A

Explanation:

The command restores the original character of Font, which has been replaced with the user-defined character set by ESC % command. However the user-defined character is still in RAM and can be called back by the ESC % command.

Using the following BASIC program can observe the effect of ESC &, ESC % and ESC : commands.

```

10 PRINT #1, CHR$(27);"W";CHR$(2);           'Enlarge in V and H
20 PRINT #1, CHR$(27);"&";CHR$(65);         'ESC & command
30 PRINT #1, CHR$(&H02)CHR$(&H7C)CHR$(&H40);
40 PRINT #1, CHR$(&HC0)CHR$(&H40)CHR$(&H00);
50 PRINT #1, CHR$(27);"%";CHR$(65)CHR$(65)CHR$(0); 'ESC %
    command
60 PRINT #1, CHR$(65)                         'Print defined character
70 PRINT #1, CHR$(27);":";                     'ESC :command
  
```

80 PRINT #1, CHR\$(65)

'Restore the font character

The printout of running the program in TP UP-PN printer is shown below:

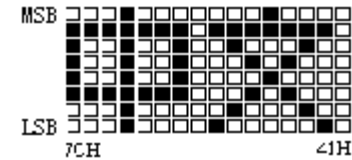

3.6 Printing Graphics Commands

ESC K		Set bit-map graphics					
Format:	ASCII	:	ESC K	n1	n2	...	data ...
	Decimal	:	27 75	n1	n2	...	data ...
	Hexadecimal	:	1B 4B	n1	n2	...	data ...

Explanation:

The command set a $n1 \times 8$ dot-matrix graphics. The width of the graphics is $n1$ dots and the height is 8 dots. The 8 dots in each column can be indicated by an 8-bit byte. The MSB is at the top position.

The value of $n1$ and $n2$ indicates a 16-bit binary code. $n1$ is used as the lower byte and $n2$ the higher byte. The width of the bit-map graphics set by ESC K command is determined by the formula $n2 \times 256 + n1$. According to printer TP UP-PN, $n2$ should be 0 and $n1$ should range among 1 to the maximum number of dots in one line specified by the model of printer.

The value of data corresponds to the byte of each dot column. The quantity of bytes should equal $n1$.

For example: Printing two Chinese characters “中文” (Chinese) with ESC K. The dot matrix of these two characters is shown as below. Each character is composed of the 7X8 dot matrix in which dot columns are 7. There is one dot-column space between two continual characters. So there are total 15 dot columns and then $n1=15$, $n2=0$. All 15 bytes of the data indicated by hexadecimal are shown as follows:

7C, 44, 44, FF, 44, 44, 7C, 00, 41, 62, 54, C8, 54, 62, 41.

The following BASIC program is in terms of the above instance.

```

10 PRINT #1, CHR$(27);"W";CHR$(2);      'enlarge in V & H
20 PRINT #1, CHR$(27);"K";CHR$(15)CHR$(0);  'ESC K
30 FOR I=1 TO 15
40 READ D: PRINT #1, CHR$(D);          'Input 15 bytes of data
50 NEXT I
60 PRINT #1, CHR$(13);                'Input CR
70 DATA &H7C,&H44,&H44,&HFF,&H44,&H44,&H7C,0
80 DATA &H41,&H62,&H54,&HC8,&H54,&H62,&H41

```

The printout in TP UP-PN is shown below:



ESC '		Print curving graph lines							
Format:	ASCII	:	ESC '	m	n1	n2	...	nk	CR
	Decimal	:	27 39	m	n1	n2	...	nk	13
	Hexadecimal	:	1B 27	m	n1	n2	...	nk	0D

Explanation:

The command prints curving graph lines along direction of paper feeding. The value of m is the quantity of curves. It ranges from 1 to the maximum number of dots in one line specified by the model of printer. (Seeing at Section 1.1)

There are m dots in a horizontal dot line. $n1, n2 \dots nk$ represent positions of m curves. The value of nk should equal the value m .

Each nk should be in the range of to the maximum number of dots in one

line specified by the model of printer. The last datum CR is used to make printer print one dot-line. The entire graph with m pieces of curves can be printed out with dot-line one by one, in which each single dot-line data is composed of data: n1, n2..nk.

For example, if wanting to print following curving graph lines decided by 5 equations:

$$Y1=50+40*EXP(-0.01*X)*SIN(X/10)$$

$$Y2=50-40*EXP(-0.01*X)*SIN(X/10)$$

$$Y3=50$$

$$Y4=50+40*EXP(-0.01*X)$$

$$Y5=50-40*EXP(-0.01*X)$$

You can use following program for showing the above curves:

```
10 FOR X=0 TO 150      'Print 150 dot lines
20 Y=INT(40*EXP(-0.01*X))
30 YY=INT(Y*SIN(X/10))
40 PRINT #1, CHR$(27);CHR$(39);CHR$(5); 'ESC 'command , m=5
50 PRINT #1, CHR$(50+YY);CHR$(50-YY);CHR$(50);
60 PRINT #1, CHR$(50+Y);CHR$(50-Y);CHR$(13);
70 NEXT X
```

The printout of running above program in TP UP-PN printer is as below:

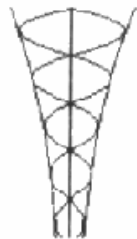

Paper feeding direction

3.7 Initialization Command

ESC @		Initialize printer
Format:	ASCII : ESC @	
	Decimal : 27 64	
	Hexadecimal : 1B 40	

Explanation:

The command initializes printer with following actions:

- clear printer buffer ;
- restore default values ;
- select font 1 ;
- erase user-defined characters.

3.8 Data Control Commands

CR		Carriage Return
Format:	ASCII : CR	
	Decimal : 13	
	Hexadecimal : 0D	

Explanation:

All data in the buffer will be printed and the paper will be fed one line forward when sending a CR command to the printer.

CAN		Cancel one line
Format:	ASCII : CAN	
	Decimal : 24	
	Hexadecimal : 18	

Explanation:

The command cancels all characters preceding this code in the line buffer and urges buffer pointer move back to the last Carriage Return code. It does not cancel any control code sequence in the line.

NUL		Null - Ending mark
Format:	ASCII : NUL	
	Decimal : 0	
	Hexadecimal : 00	

Explanation:

The NUL command needs to combine several commands and ends those commands, for example ESC B, ESC D, and ESC %. It would be no effect if issuing alone.

3.9 Hexadecimal Dumping Command

ESC "		Turn Hexadecimal Dumping on/off	
Format:	ASCII	:	ESC " n
	Decimal	:	27 34 n
	Hexadecimal	:	1B 22 n

Explanation:

If n=1, then turn on the hexadecimal dumping. If n=0, then turn off it. All data received from the host computer will be printed out in hexadecimal at the hexadecimal dumping mode.

For example, when host computer sends following 4 data to printer by the statement:

```
PRINT #1, CHR$(0);CHR$(27);"A";CHR$(24);
```

The data will be printed out with hexadecimal as follows:

```
00 1B 41 18
```

The hexadecimal dumping begins to print only when the printing buffer is full.

3.10 Chinese Character Printing Commands

FS &		Enter Chinese Printing Mode	
Format:	ASCII	:	FS &
	Decimal	:	28 38
	Hexadecimal	:	1C 26

Explanation:

This command is used to enter Chinese Character Printing mode. After receiving this command, printer ends the current line printing and start Chinese character printing next line.

FS ?		Exit Chinese printing Mode	
Format:	ASCII	:	FS ?
	Decimal	:	28 46
	Hexadecimal	:	1C 2E

Explanation:

This command is used to exit Chinese Character Printing mode. After receiving this command, printer enters ASCII code mode.

FS S0		Set Chinese Double-width Print	
Format:	ASCII	:	FS S0
	Decimal	:	28 14
	Hexadecimal	:	1C 0E

Explanation:

Printer will print out Chinese characters in double-width when receiving this command, till receiving the command 'FS DC4', 'CR' or 'LF' and quit Chinese double-width print mode.

FS DC4		Cancel Chinese Double-width Print Mode	
Format:	ASCII	:	FS DC4
	Decimal	:	28 20
	Hexadecimal	:	1C 14

Explanation:

Cancel Chinese double-width print mode.

3.11 Black Mark Detecting Command

GS FF		Detect black mark and feed to next page top	
Format:	ASCII	:	GS FF
	Decimal	:	29 12
	Hexadecimal	:	1D 0C

Explanation:

The printer enters Black Mark Detecting Mode when it receives this command. The printer detect the black mark in the rang from the beginning to 200mm of this page. Feed paper to the beginning of next page if the printer has detected the Black Mark, or it will stop feeding paper and indicate no black mark is found out.

After power on, printer default the black mark has been at the paper tear bar. The content to be printed should be between two black marks in sequence.

This command is valid only on using the paper with pre-printed black mark.

Notice for black mark printing:

The black mark should be printed on the printing side of the paper. The position of the black mark is the paper tearing line.

The position and size of the black mark printed are shown as below picture.

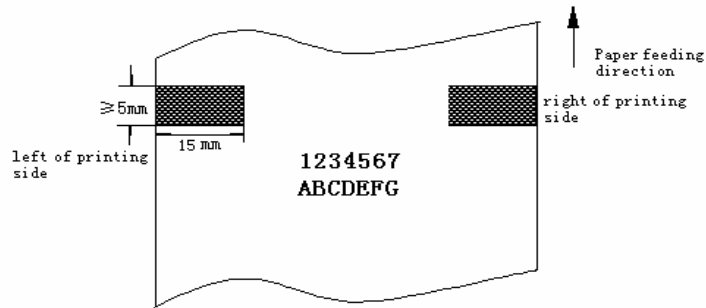

The reflectivity of the black mark printed should be less than 10%, and the others along the feeding direction should be more than 75%.

Explanation for printing area:

Printing area is shown as below figure.

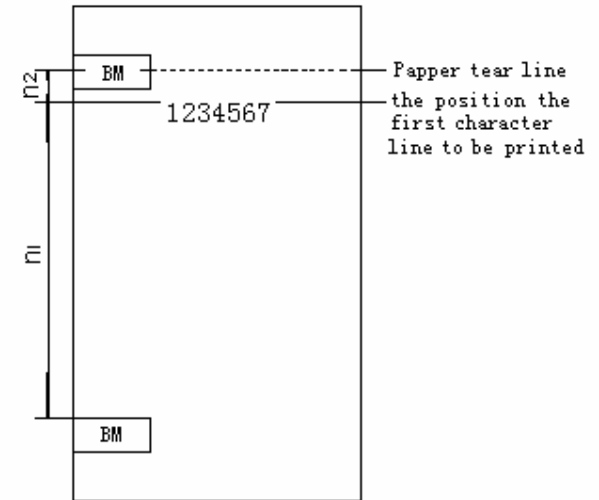

n1: valid printing area.

n2: distance from the first printing line to the paper tearing line. n2=20mm.

Chapter 4 Battery Charge and Discharge

4.1 Battery

The printer uses a rechargeable battery with DC 6V 1500mAh.

4.2 Charging Method

Two charging methods are used for charging the battery: slow charging on the printer and external quick charging.

1.Slow charging on printer

Connect an external adaptor of DC12V/600mA to the DC jack of the printer, and the battery is installed on the printer. The charging time need 12-16 hours.

2.External quick charging

Take out the battery from the printer and put it on the optional CX-101 Quick Charger, connect the adaptor of DC12V/600mA to the Charger. The charging time need 4 hours. There are 4 indicators on the CX-101 quick charger for indicating the status of the charging. More indicators light, more power charged.

4.3 Discharging Method

When the printer can't work correctly due to the battery low, there may be some power in the battery. To reduce the remember effect of the battery and keep the capacity of the battery, strongly recommend charging after discharging sufficiently.

1.Discharging on printer

After power off, press and hold button ON more than 10 seconds until the both of red and green indicator light, the printer enters into discharging state and can't do any operations. When the both of indicators are off, the discharging finished.

2.External quick discharging

CX-101quick charger has a quick discharging function. Put the battery on the charger, press the button located left and down corner. The battery enters quick discharging and then enters quick charging automatically after finished discharging.

4.4 Method of getting back the capacity

If the battery discharged not entirely (the printer can work or the battery is discharged not sufficiently before charging) and charged not entirely (the charging time is not enough) more times, the battery capacity will reduce due to Ni-MH battery have some remembrance effect. To get back the capacity of the battery, 2 or 3 times of charging and discharging entirely are necessary. The method of discharging and charging the battery is same as descriptions of section 4.2 and 4.3.

Chapter 5 Notice about the IrDA Infrared Interface

When use the IrDA infrared interface the user must notice the following:

1 The communication parameter must meet the following

Baud rate: 9600bps

Data bit: 8

Parity: none

Stop bit: 1

2 Make sure the infrared windows of the host and printer aim each other, that is the View angle must within 30 °

3 Insure there is no obstacle between the host and printer, and the distance must within 1 meter.

4 If the clobber and lost data occurred, refer to the section 1,2,3 above

5 If the printer doesn't work when use the IrDA infrared interface, may sure the RS-232 communication cable has been plugged out.

Chapter 6 Notice about the Rechargeable Ni-MH Battery

6.1 Ni-MH Rechargeable Battery characteristics

6.1.1 Charging characteristics

The charging characteristic is affected by the current、 temperature、 time etc. The current and the temperature affect Ni-MH rechargeable battery charging characteristics obviously, temperature drop down or current increase may cause the charging voltage rise.

We recommend you charge the battery with the current within 1C (1C = 1500mA) , the temperature within 0°C~40°C. Charging the battery usually in the temperature exceed the range will lower the capability of the battery. Overcharge the battery from time to time may be underutilized resulting insufficient use of the available capability.

6.1.2 Discharging characteristics

The Ni-MH rechargeable battery is similar to the Ni-Cd rechargeable battery. The discharge voltage is about 1.2 volt. The discharging characteristics is affected by the current、 temperature etc. The higher discharge current and lower temperature the lower discharge voltage and efficiency. The maximum continuous discharge current is 3C.

6.1.3 Cycle life characteristics

Cycle Life of the battery is more than 500 times when it use correctly. The battery is chemical, the capacity will be dropped down after use for many times also longtime storage. Incorrect use may drop down the cycle life of the battery.

6.1.4 Storage characteristics

The storage characteristics include the self discharge characteristic and long time storage characteristic.

Self discharge indicates the phenomenon that the battery discharge in open circuit. The self discharge characteristic is affect by the environment.

Research indicates that it is the best to store the battery with full charge status. The battery should be stored in the temperature about 10 ~ 30°C and the

relative humidity about 45% ~ 85%. Store in high temperature may cause leakage, store in high relative humidity may cause corrode.

The capacity of the battery may be lower after along time storage. Charge and discharge the battery for several times can get back the capacity. We recommend you discharge and charge the rechargeable battery for one time at least when you have stored the battery more than half year.

6.2 Notice:

6.2.1 Charging

1) The charging efficiency is affected by the environment. Charging in the temperature about 10°C ~ 30°C may has the best efficiency. It may cause the leakage, lower the capability or the cycle life of the battery if charge it in the temperature under zero. The charge efficiency may drop sharply when charge the battery in the temperature higher than 40°C, also it will cause the leakage, lower the capability of the battery. It may cause leakage and lower the capacity if charge the battery in the temperature too high.

2) Never short circuiting the cells, use the correct polarity when charging, or it may cause the deformation, leakage even the explosion.

3) The maximum current of external quick charging must within 1C. must use the specified adapter to charge the battery or it may cause overheating, leakage, even explosion.

4) The range of current slow charging on printer should be 1/30C ~ 1/20C. The charging time should not exceed 20 hours.

6.2.2 Discharging

1 The battery discharging temperature could be -20°C ~ 60°C. The best discharging temperature is 0°C ~ 40°C

2 The best discharging current is 1/10C ~ 1C, the maximum continuous discharge current should not exceed 3C. Too high discharging current may drop down the discharging efficacy and heat the battery.

3 Do not over-discharging, it may cause leakage, drop down the cycle life even cause explosion.

Explanation:

C=rated charging current (or discharging current)/hour
=rated capacity mAh/h

For example: for a 1500mAh battery,

1C=1500mA

0.4C=600mA

0.1C=150mA

Appendix 1 Specifications

- Printing method: Dot matrix printing
- Printing mechanism: 8 pin shuttle head
- Printing width: 57.5mm
- Printing paper: (normal paper, paper will-ended sensor)
 - Outside diameter: 50mm
 - Inside diameter: 12.5mm
 - Paper width: 57.5 ± 0.5mm
 - Paper thickness: 53 ~ 64g/m²
- Copy ability: 1(original)+1
- Ribbon cassette: ERC-09 (purple), life: 250 thousand characters
ERC-22 (purple), life: 1000 thousand characters
- Printing characters:
 - 448 defined characters
 - 32 user-defined characters
 - GB level 1 and level 2 Chinese font(15 × 16dot matrix)
- Printing commands: ESC/P printing control commands and FS Chinese printing control commands.
- Interface:
 - Serial interface: RS-232C, RJ-11 modular jack; RTS/CTS handshaking baud rate 9600bps.
 - Infrared interface: Communication distance: 1.0m (max.). Communication angle: 30°
- Supply power: DC 6V 1500mAh rechargeable battery.
- Overall dimension: 153(L) × 116(D) × 65(H)
- Weight: About 530g (excluding the paper roll)
- Working condition: Temperature 0 ~ 50°C, relative humidity 10-80%

Appendix 2 Printing Control Commands

Decimal	Hexadecimal	Command	Description
0	00	NUL	Ending mark
9	09	HT	Horizontal tab
10	0A	LF	Line Feed
11	0B	VT	Vertical Tab
12	0C	FF	Form Feed
13	0D	CR	Carriage Return
14	0E	SO	Set double width of character
20	14	DC4	Cancel double width of character
24	18	CAN	Cancel current character-line
27 34	1B 22	ESC " n	Turn Hexadecimal Dumping on/off
27 37	1B 25	ESC % m1 n1..mk nk NUL	Replace with user-defined character
27 38	1B 26	ESC & m n1 n2..n6	Defined user-defined character
27 39	1B 27	ESC 'm n1 n2...nk CR	Print m curving graphic lines
27 45	1B 2D	ESC - n	Turn underline on/off
27 49	1B 31	ESC 1 n	Set 'n' dot-line spacing
27 54	1B 36	ESC 6	Select Font 1
27 55	1B 37	ESC 7	Select Font 2
27 58	1B 3A	ESC :	Restore the font character
27 64	1B 40	ESC @	Initialize printer
27 66	1B 42	ESC B n1..nk NUL	Set vertical Tabs
27 67	1B 43	ESC C n	Set page length to equal to n lines

27 68	1B 44	ESC D n1..nk NUL	Set Horizontal tabs
27 74	1B 4A	ESC J n	Perform ' n' dot-line feed
27 75	1B 4B	ESC K n1 n2..data...	Set a n1 x 8 dot-matrix graphics
27 78	1B 4E	ESC N n	Set bottom margin
27 79	1B 4F	ESC O	Cancel bottom margin
27 81	1B 51	ESC Q n	Set right margin
27 85	1B 55	ESC U n	Enlarge in width
27 86	1B 56	ESC V n	Enlarge in height
27 87	1B 57	ESC W n	Enlarge in width & height
27 99	1B 63	ESC c n	Inverse printing
27 102	1B 66	ESC f m n	Print blank character or blank line
27 105	1B 69	ESC i n	Turn reverse printing on/off
27 108	1B 6C	ESC I n	Set left margin
28 14	1C 0E	FS S0	Set Chinese Double-width Print Mode
28 20	1C 14	FS DC4	Cancel Chinese Double-width Print Mode
28 38	1C 26	FS &	Enter Chinese Character Mode
28 46	1C 2E	FS .	Exit Chinese Character Mode
29 12	1D 0C	GS FF	Detect black mark and feed to next page top

Appendix 3 Character Code Tables

Character code table 1

	0	1	2	3	4	5	6	7	8	9	A	B	C	D	E	F
2	!	"	#	\$	%	&	'	<	>	*	+	,	-	.	/	
3	0	1	2	3	4	5	6	7	8	9	:	;	<	=	>	?
4	a	b	c	d	e	f	g	h	i	j	k	l	m	n	o	
5	p	q	r	s	t	u	v	w	x	y	z	[\]	^	_
6	`	a	b	c	d	e	f	g	h	i	j	k	l	m	n	o
7	p	q	r	s	t	u	v	w	x	y	z	()	~		
8	9	ü	e	ä	ä	ä	9	8	e	e	i	i	ä	ä		
9	e	e	ö	ö	ö	ö	ö	ö	ö	e	e	e	e	e	e	e
A	ä	i	ö	ü	ä	ä	e	ö	c	r	z	k	i	<	>	
B	ü	ü	ü	ü	ü	ü	ü	ü	ü	ü	ü	ü	ü	ü	ü	ü
C	L	L	L	L	L	L	L	L	L	L	L	L	L	L	L	L
D	ü	ü	ü	ü	ü	ü	ü	ü	ü	ü	ü	ü	ü	ü	ü	ü
E	ü	ü	ü	ü	ü	ü	ü	ü	ü	ü	ü	ü	ü	ü	ü	ü
F	ü	ü	ü	ü	ü	ü	ü	ü	ü	ü	ü	ü	ü	ü	ü	ü

Character code table 2

	0	1	2	3	4	5	6	7	8	9	A	B	C	D	E	F
2	-	二	三	四	五	六	七	八	九	十	百	千	万	元	角	分
3	ア	イ	ウ	エ	オ	カ	キ	ク	ケ	コ	サ	シ	ス	セ	ソ	
4	タ	チ	ツ	テ	ト	ナ	ニ	ノ	ハ	ヒ	フ	ヘ	ホ	マ	ミ	ム
5	メ	ム	エ	オ	カ	キ	ク	ケ	コ	サ	シ	ス	セ	ソ	タ	チ
6	ン	フ	ウ	エ	オ	カ	キ	ク	ケ	コ	サ	シ	ス	セ	ソ	
7	ハ	ヒ	フ	ヘ	ホ	マ	ミ	ム	メ	モ	ヤ	ユ	ヨ	ラ	リ	ル
8	レ	ロ	ワ	ヰ	ヱ	ヰ	ヱ	ヰ	ヱ	ヰ	ヱ	ヰ	ヱ	ヰ	ヱ	ヰ
9	ヱ	ヰ	ヱ	ヰ	ヱ	ヰ	ヱ	ヰ	ヱ	ヰ	ヱ	ヰ	ヱ	ヰ	ヱ	ヰ
A	上	下	中	左	右	前	後	内	外	東	西	南	北	東	西	南
B	□	○	△	▽	◇	◇	◇	◇	◇	◇	◇	◇	◇	◇	◇	◇
C	□	○	△	▽	◇	◇	◇	◇	◇	◇	◇	◇	◇	◇	◇	◇
D	↑	↓	↖	↗	↘	↙	↘	↙	↘	↙	↘	↙	↘	↙	↘	↙
E	・	・	・	・	・	・	・	・	・	・	・	・	・	・	・	・
F	...	()	!	@	#	\$	%	&	'	()	!	@	#	\$