

4" Easy-Loading Thermal Printer

GPT-4454

MAXI MULDE

RS232 • Infrared • USB • Bluetooth®

Real Time Clock • Magnetic Card Reader

OPD-Menue®

Intelligent Power Management

Robust Housing

GeBE®

**Elektronik und
Feinwerktechnik GmbH**

Module und Geräte zum Eingeben,
Auswerten, Anzeigen und Ausdrucken
analoger und digitaler Daten.

GeBE Document No.:
SMAN-E-510-V1.1b

Status: 27.10.2005

Printed: 04.11.2005

German: **SMAN-D-504**

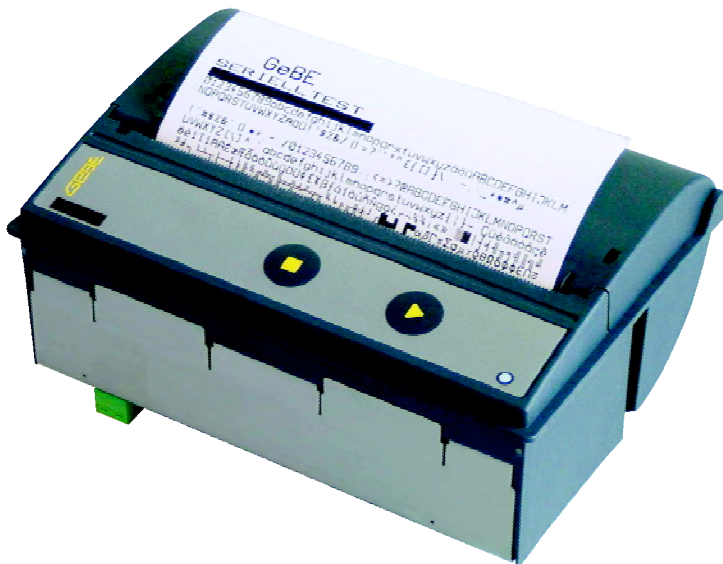

Technical Manual

Activities at GeBE

Printers: GeBE Elektronik und Feinwerktechnik GmbH • E-Mail: sales.ef@gebe.net • www.oem-printer.com

Keyboards: GeBE Computer & Peripherie GmbH • E-Mail: sales@tastaturen.com • www.tastaturen.com

Internet Applications: www.GeBE.net

The GeBE logo is a registered trademark of GeBE Elektronik und Feinwerktechnik GmbH. All other brands named in this brochure are properties of the respective companies. Errors and changes reserved. The technical data given are non-committal information and do not represent any assurance of certain features. Our terms of payment and delivery apply.

Copyright © 2005 GeBE Elektronik und Feinwerktechnik GmbH. All rights reserved.

GeBE Elektronik und Feinwerktechnik GmbH

Beethovenstr. 15 • 82110 Germering • Germany • www.oem-printer.com

Phone: ++49 (0) 89/894141-0 • Fax: ++49 (0) 89/8402168 • E-Mail: sales.ef@gebe.net

Content

1	Safety Instructions	3	6.2.2 PIN Assignment at the 25pin SUB-D of the Adapter	9
2	Description	4	6.2.3 Timing of the Parallel Interface	9
3	Packing List	4	6.3 Infrared Interfaces	10
4	Installation	5	6.4 USB Interface	11
4.1	Installation in a Front Panel	5	6.5 Bluetooth® Wireless Technology	12
4.2	Partial Installation in a Plastic Housing	5	7 Operation	13
5	Connection • Installation	6	8 Button Functions	14
5.1	Power Supply	6	9 A Guide Through the OPD-Menue®	14
5.1.1	Fixed Voltage Operation with Integrated DC/DC Converter 10-20VDC or 18-36VDC	6	10 Jumper for Power-Down Mode Setting	16
5.1.2	Operation Through 4.5-8.5VDC Fixed Voltage or Battery	6	11 Status Messages Through LEDs	17
5.1.3	Installation of an External Battery	6	12 Batch Files	18
5.2	GPT-4454 Power Management	6	13 Option Magnetic Card Reader	19
5.3	Charging the GPT-4454	7	14 Character Sets	20
5.3.1	How to Handle Batteries	7	15 Accessories and Spare Parts	21
6	Interfaces	8	16 Service	21
6.1	Serial Interfaces	8	17 Troubleshooting and Recovery	22
6.2	Parallel Interface	9	18 CE Certification	23
6.2.1	Centronics Adapter with SUB-D 25 pin Connector	9	19 Technical Data	24
			18 Mechanical Dimensions	24

The technology and configuration of the product described in this manual comply with the latest national and international standards regarding both functionality and safety. Advancements and improvements are incorporated regularly, and, therefore, illustrations, measurements, technical data, and general contents mentioned below are subject to change without notice.

These operating instructions will help you to operate our product, which has been developed and manufactured in accordance with the latest technology, providing for the most optimal and safest operation. Please read this manual carefully before operating the product for the first time, and keep it available in order to reference it when needed.

If you have any further questions, please contact our staff. You can find all necessary phone numbers and email addresses in the chapter "Service and Maintenance".

Symbols and Their Meaning

Carefully read all safety instructions marked with a , as well as all important information marked with a .

Safety instructions  affect your **personal safety** and **must be observed at all times**. It is essential to forward these instructions to all other personal using this device.

Important information  refers to **equipment safety**.

The adherence of all instructions, as well as the appropriate application and use in accordance with the operating instructions are binding for product liability and product warranty. Attempts by the customer to repair the device will make all warranty claims null and void.

For technical questions, please contact GeBE Technical Support

Instructions marked with a  require consultation with GeBE Technical Support.

Tips are marked with a  and will help you to utilize your printer to its fullest.

Documents or Internet links are marked with a , referring to more detailed or additional information.

1 Safety Instructions



Attention

Safe operation of this device is only warranted, if the instructions in this operating manual have been complied with.

For installation: Always disconnect system power supplies.

Only use manufacturer's parts and accessories.

- The device may only be opened or repaired by authorized personal. Never open the device or carry out repairs yourself. Always contact an authorized technical servicer.

You can find all necessary service information in the chapter "Service and Maintenance".

- Before the device is turned on, make sure that the system voltage of your installation matches the supply voltage of the device. The device characteristics are printed on the name plate and in the technical data.

- The name plate is located on the underside of the device.

- For the technical data of the device, refer to the chapter "Technical Data".

- The peripheral devices that are connected to the interfaces and the DC circuits of this device have to meet the requirements for extra-low safety voltage (SELV) with limited power in accordance with EN/IEC 60950.

- Make sure that the printer is protected against over-voltage in accordance with EN/IEC 60950t.

- Switching off the device does not completely disconnect it from the power supply. Your device is only disconnected completely, when the power plug is unplugged.

- Please make sure that the power supply cable is run in a way that nobody trips over it, and it cannot be damaged by other devices.



- It is no longer possible to safely operate the device, if:
 - the housing has been damaged due to mechanical overload.

- moisture reached the inside of the device
 - smoke is coming from the inside of the device
 - the power supply cord is damaged
 - the device stopped working properly.

Turn off the device immediately, when such a failure occurs, and contact GeBE customer service. See chapter "Service and Maintenance".

- We explicitly state that all product liability and guarantee claims are null and void, if the device has not been used in accordance with the instructions in this operating manual or on the device itself, or if it has been used inappropriately.



- Risk of explosion in case of incorrect battery exchange.



- During operation, surfaces in the surrounding area of the print head may heat up. Therefore, direct contact with the print head must be avoided to prevent burning accidents.

Do not put heat sensitive objects close to this heat source.

- Avoid constant high humidity and condensation. Protect the device from being splashed and from getting in contact with chemicals.

- Only use spare parts and accessories supplied or authorized by GeBE. The use of unauthorized parts or accessories may considerably affect the function and safety of the device. All parts included are listed in the chapter "Packing List", while the original accessories are listed in the chapter "Parts and Accessories".



- The printer versions with an infrared interface contain a light emitting diode of laser category I. This infrared transmitter does not pose a threat for the human eye or skin, even with long periods of exposure.

- The device complies with laser category I in accordance with EN60825-1/A2:2001

- It is prohibited to operate the device, if the housing is damaged. If this occurs, please contact GeBE Service. You can find the information under "Service and Maintenance". For the description of the infrared interface, please refer to page 10.

2 Description

The GPT-4454 is an industrial printer for installation in a robust plastic housing reinforced with fiber glass. The foil on the operating console can be printed with a custom design.

Due to the extended temperature range of -10 to +60 °C, MAXI MULDE is ideal for outdoor applications.

Easy paper roll exchange due to Easy Paper Loading technology. The paper supply lid closes securely shut (tested in accordance with DIN EN60068-2-6 vibrations, and -29 constant shock).

A convenient OnPaperDisplay menu (OPD-Menue[®]) replaces the earlier configuring of the printer through DIP switches

Besides wireless interfaces such as Bluetooth[®], IrDA, or GeBE-Ir, MAXI MULDE can also be controlled through a RS232 or USB interface.

The printer can be equipped with a battery charging circuit for 5 NiMH cells or 2 Li-Ion cells. Charging will take about 4 hours.

Intelligent power management increases the operational readiness. The printer can switch to a sleep mode that will still allow it to receive data. In sleep mode, the power consumption can be lower at times than the self-discharge of the battery.

The alarm timer of the optional real time clock of the MAXI MULDE wakes up the printer at the programmed time to perform a previously defined action. The GPT-4454 is also available with a 3-track magnetic card reader and/or a paper rewinder.

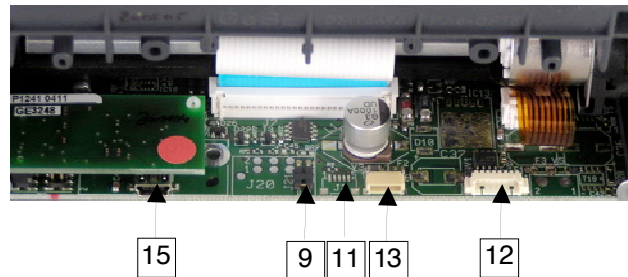
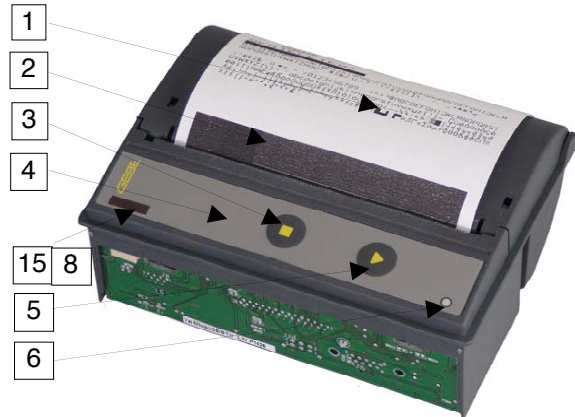
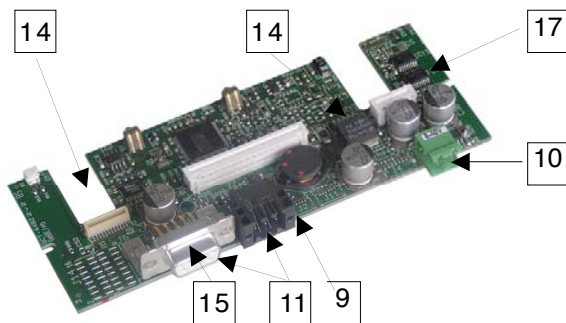

Parts and Functions of the Printer *)

- 1 opening lever for paper supply lid (LEVER)
- 2 paper supply lid
- 3 button {OFF/NEXT}
- 4 button {SET} currently without function
- 5 button {FEED/ENTER}
- 6 LED "STATUS" (green/red)
- 7 LED "communication" (red)
- 8 Window for IR transmitter/receiver
- 9 sleep jumper of DC/DC version
- 10 power supply: 10-20 / 18-36V Phoenix connector
- 11 serial interface RS232 (3 different types)
- 12 power supply 4.5 - 8.5 VDC or battery plug connection
- 13 connector for charger
- 14 SPI Bus connector
- 15 USB connector
- 16 rewinder
- 17 IrDA external transmitter/receiver

*) applies to the whole document: features depending on the printer version (GPT-4454)

3 Packing List

Please check during the unpacking process, if all parts have been delivered completely and undamaged. Make sure to remove all parts from the packaging. Claims for damages caused during transport can only be asserted, if the carrier is informed without delay. Please prepare a survey report and send it back to the supplier along with the damaged part.

Standard Versions of the Thermal Printers

The OEM printers of the MAXI MULDE series do not include any accessories.

Please order accessories separately according to the table in the chapter "Parts and Accessories" on page 21.

Possible Configurations of the GPT-4454 Printer Series for OEM

No. (see below)	The GPT-4454 series is equipped with controller board GCT-4482 (various options available)	EEPROM KB							Functions							Interfaces							Options	
		fixed voltage 10 -20 V	fixed voltage 18 -36 V	fixed voltage 4.5 - 8.5 V	battery pack 5x NiMH	Li-ION battery	battery charged with GeBE power supply	number of buttons	DUO LEDs	IR communications LED	OPD settings menu	batch files TINIT/LOGO's	clock with timer function	RS422/485	RS232	TTL	IrDA	Centronics	GeBE-IR-Protocol	Bluetooth	USB	paper rewinder	extended SPI Bus	
1	GPT-4454-V.24-DC/DC10-20	x	-	-	-	-	-	2	x	-	x	x	**	**	x	-	-	-	-	-	-	**	x	
2	GPT-4454-V.24-DC/DC18-36	-	x	-	-	-	-	2	x	-	x	x	**	**	x	-	-	-	-	-	-	**	x	
3	GPT-4454-V.24	-	-	x	x	**	x	2	x	-	x	x	**	**	x	-	-	-	-	-	-	**	x	
4	GPT-4454-Ir	-	-	x	x	**	x	2	x	x	x	x	**	**	-	-	x	-	x	-	-	**	x	
5	GPT-4454-Ir-BT	-	-	x	x	**	x	2	x	x	x	x	**	**	-	-	x	-	x	x	-	**	x	
6	GPT-4454-USB	-	-	x	x	**	x	2	x	-	x	x	**	**	-	-	-	-	-	-	x	**	x	
7	GPT-4454-Centr.	-	-	x	x	**	x	2	x	-	x	x	**	**	-	-	-	x	-	-	x	**	x	

**) = Option



- Before initial operation, please make yourself familiar with the chapter "Safety Instructions".
- The characteristics of your system voltage must match the characteristics of your device.

4 Installation

4.1 Installation in a Front Panel

The printer GPT-4454 can be installed with two screws in an easily done front panel cut-out of with a thickness of up to 4 mm. The contact surface is flat. The edge of the housing juts out by 1 mm, covering the space between the housing wall and the panel and the plastic housing.

The plastic housing is pushed into the cut-out **from the outside**. Then, it can be easily mounted to two mounting plates.

The two 2.8 mm holes allow the use of M 2.5 screws.



4.2 Partial Installation in Plastic Housing

As shown in the picture on the left, the printer housing can also be installed at the edge of a casing. This installation variation has the part of the printer housing that contains the paper roll extending beyond the unit casing. This saves room in the device casing for the installation of other components.

To facilitate installation in different casing shapes, the outer wall of the paper storage was left smooth below the bearing collar. The housing can project about 19 mm from the casing edge, since about half of the paper storage can be used, right up to the slanting slot for inserting the mounting plate.

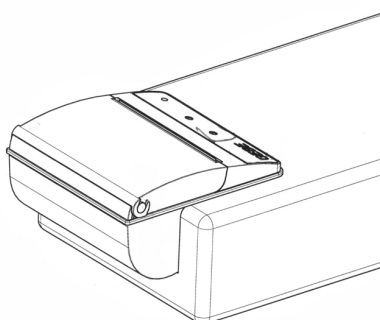

5 Connection . Installation

During installation:

Always disconnect the power !

5.1 Power Supply

The printer can either be supplied with a fixed voltage from a power supply or from a battery .

5.1.1 Fixed Voltage Operation with integrated DC/DC converter 10 - 20 VDC or 18 - 36 VDC

Socket	Nb	Signal	Comment
(10)	1	GND	Power GND
	2	VP	Power VP: External power supply from 10 to 36 VDC (max. 8 - 40V)

The GPT-4454-DC/DC has an integrated DC/DC converter with an input voltage range of 10-20 VDC or 18-36 VDC, depending on the type. The DC/DC supply is connected to socket 10 (see pictures in chapter 2). The voltage inputs are protected against reverse polarity and secured through a PTC. The connected voltage supply has to be protected against overvoltage in accordance with EN/IEC 60950. Suitable power supplies for these variants are available from GeBE.

5.1.2 Operation through 4.5 - 8.5 VDC Fixed Voltage or Battery on 7 pins Molex connector

Socket	Nb	Signal	Comment
(12)	1	GND	Power GND
	2		
	3		
4	4	VP	Power VP. Regulated Voltage from 4,5 to 8,5 VDC
	5		
	6		
7	NTC	Input for a NTC 6,8 K Ω temperature sensor for the battery pack	

In order to comply with EN/IEC/UL60950, the power supply may **ONLY** be connected with the cable GKA-517 and **MUST** meet the requirements for power supplies for limited power due to design. For installation conforming to standards , please also regard the instructions of the UL60950 and in our manual SMAN-E-529. Only the battery GNA-6,0V-1,6Ah-NiMH-Pack-070 may be connected.

Battery or power supply are connected with the same connector 12 (3 red wires for +4.5/8.5 VDC, 3 black wires for ground, and one white wire for an NTC 6.8 K Ω of a Ni-MH battery; see pictures in chapter 2). For a simple power connection, the white cable has no function. It is recommended to keep the length of the line as short as possible. A line that is too long has a high line resistance , causing bad print quality , and possibly even printer failure.

The battery pack consists of 5 cells NiMH Mignon (AA) with 1,600 mAh. A temperature sensor monitors the battery temperature during the charging process. An integrated bi-metal over-current circuit breaker protects against short circuits and overheating.

Installation of an External Battery

For installation of batteries, the following guidelines apply:

- When a battery is installed , sufficient surface area for heat dissipation is essential.
- The battery has to be mounted stationary .
- Only batteries from GeBE or authorized by GeBE may be used.
- The cables have to be mounted unstrained.

5.1.3 Battery Ni-MH charging Voltage

Socket	N°	Signal	Comment
(13)	1	GND	Power GND
	2		
	3		
4	4	VP	Power VP
	5		
	6		

The battery charging voltage is connected through socket 13 (see pictures in chapter 2). The specified plugin power supply is attached to the connecting cable and the matching connector. With a fully charged 1,600 mAh battery , up to about 40 m of thermal paper can be printed with normal text.

5.2 GPT-4454 Power Management

Whenever there are no data to process, the printer will automatically switch to idle mode. In this mode, it acts 100% active and can receive data without delay . The power consumption in this mode is typ. 5 mA.

Sleep Mode

If a sleep time has been set via menu, the printer will switch to the power-down mode after the expiration of this time. Any kind of data transfer (even infrared), activity on control lines, connecting the charger, or simply the pressing of the FEED/ENTER button will reactivate the printer immediately without the loss of any settings. Only the print buffer is erased. The necessary activation and waiting for the appropriate ready message from the printer has to be accounted for in the printer drivers. The power-saving sleep mode can be turned on or off through the following functions:

- settings menu
- command from the host or from the batch file TINIT

Power Off

When the "OFF/NEXT" button is held down for more than three seconds, the printer is completely turned off. It is turned on by pressing the FEED/ENTER button, or by connecting the charger . Optionally, the printer can be configured, so that it can also be turned on through the RTS line.

5.3 Charging the GPT-4454

The GPT-4454 has an intelligent charging circuit without current limitation . The current limitation is ensured through the use of the included power supply .

The charging process is divided into three steps.



The inserted batteries require at least 3 complete charging and discharging cycles in order to reach their maximum capacity. Incomplete charging and discharging cycles during operating will reduce the life of the battery.

Formatting Charge

If the battery is overdischarged, a formatting charge with a low voltage is started to avoid damage to the battery. The formatting charge is not displayed on the outside. The formatting process can take from 1 to 15 minutes, depending on the state of the battery.

Fast Charge

As soon as the battery voltage exceeds the operating voltage of the printer, the printer starts the fast charge. This is indicated by a slow flashing of the STATUS LED, and by a message through the interface. The charging process takes about four hours for empty batteries.

Trickle Charge

As soon as one of the stop criteria has been reached, the printer will switch to the trickle charge. In this mode, a permanent formatting current is flowing. In addition, the fast charge is activated every eight minutes for 20 seconds. This is indicated by permanent glowing of the STATUS LED and by a message through the interface.

5.3.1 How to Handle Batteries

The capacity of a battery gradually decreases due to usage, tough environmental conditions, aging, and lack of maintenance.

Just like any other battery technology, NI-MH batteries require some care in order to achieve the maximum life and to preserve the power as long as possible. Without this care, the cells will quickly become highly resistive with their capacity noticeably decreasing. In high current applications like thermal printers, NI-MH batteries reach about 500 charging cycles maximum. However, the available energy starts to distinctly diminish from about 200 - 300 cycles.

The Correct Handling of a Ni-MH Battery: Charging:

NI-MH batteries are extremely sensitive to any kind of over-charging. A trickle charge should only be applied, if at all, with very small currents and for short periods of time.

For technical reasons, the printer needs to be supplied with a very small charging current at all times. Therefore, it is recommended to disconnect the printer from the printer as soon as possible, after the charging process was completed. Never charge batteries outside the temperature range of 10 to 25 °C.

Overdischarged Batteries:

The printer will initially format overdischarged batte-

ries with a small charging current. For very strong discharges, this process can take up to 30 minutes. This status will not be indicated by the printer. At the beginning of the fast charge, the printer will flash 1:1. For overdischarged batteries, an effect develops at the beginning of the fast charge phase that is similar to the turning-off criteria of a full battery. For this reason, it may come to an early shutdown in rare cases. Therefore, we recommend to check for overdischarged batteries after about 30 minutes, whether the fast charge is still running. If not, please start the charging process over by unplugging and plugging back in.

Discharging/Printing:

If NI-MH batteries get overcharged with high currents, the polarity of the weakest cell will be reversed. This reversal will cause damage to the cell and, in the worst case, will lead to a short-circuit in the cell. Should your printer refuse to print because of an empty battery, you should not continue trying. Any further attempt may lead to a reversal of polarity in a cell and therefore, to the destruction of the battery.

Storage:

NI-MH batteries have an increased self-discharge. They lose 10-15% of their capacity during the first 24 hours after the charging process, and after that, 10-15% per month.

Therefore, the printer should be turned off, whenever it is not being used for longer periods of time. This is especially true for devices with Bluetooth technology. Nevertheless, the printer will have to be recharged after no more than 3 months, or the battery may get damaged.

Always store the battery with a charging state of > 50% and in a temperature ranging between 10 and 30 °C.

Regeneration:

If NI-MH batteries have not been overdischarged, they may indeed regenerate. To achieve this, the battery has to be discharged completely for about 50 charging cycles (3 months).

For this purpose, you can turn off the sleep function and let the printer discharge the battery. As soon as the printer shuts down due to low voltage, the battery should be charged immediately.



Do not print to speed up the process. This may cause the polarity of one cell to reverse, destroying the battery. Do not forget to reactivate the sleep mode afterwards.

6 Interfaces

6.1 Serial Interfaces

RS232 Interface

The interface cable that comes with the set connects to the plug-in connector 11 (see chapter 2), and directly with an RS232 connection (COM interface of a PC) on the other end. An open-ended cable with 5 single wires is available as an option.



The peripheral devices that are connected to the interfaces and the DC circuits of this printer have to meet the requirements for extra-low safety voltage (SELV) with limited power in accordance with EN/IEC 60950.

Serial RS422/485 Interface

By mounting the GCT-4482-10 module, an RS422/485 interface can be installed at the serial connectors. With the solder bridges Br1-5, the interface can be configured as RS422 or RS485. Br6 activates a 120 Ohm terminating resistor for RS422 systems.

GeBE COM

In this setting, the printer uses the GeBE-Ir protocol for communication. The protocol can be used either through the RS232 or the TTL interface. Due to the CRC guarded transmission blocks, a secure data connection can be used (also see: Infrared Interfaces).

Pin Assignment of the Serial Interface RS232 at Connector (11)

Plug-in connector at the printer: (5pin). >>> serial cable. The second end has a 9 pin SUB-D socket. The assignment is 1:1 matching the COM interface of the PC.

Pin	Signal	Input/Output	Comment	Pin Assignment GKA-406 D-SUB 9Pin
1	GND signal	GND		5
2	TXD	I	print data	3
3	RXD	O	error messages and Xon/Xoff messages	2
Auswahl über BR5	RTS	I	handshake input of the controller (standard: reactivation function)	7
	+3.0V digital	O	supply for external adapters	
	+3.0V -7.2V Power	O	supply for external adapters	
5	CTS	O	If the level is logic-true, the controller is able to receive data.	8

Timing of the serial RS232

The preset timing by default can be seen in the diagram. For the printers with EEPROM, the data format can be set via settings menu.

Standard Data Format

- 9600 baud
- 8 data bits
- NON parity bit
- 1 stop bit
- TX line on

Selectable Data Formats

- 1,200; 2,400; 4,800; 9,600; 19,200; 38,400; 57,600; 115,200Bd
- 7/8 data bits
- odd, even, non parity bit
- 1, 2 stop bits
- TX line switched ON/OFF

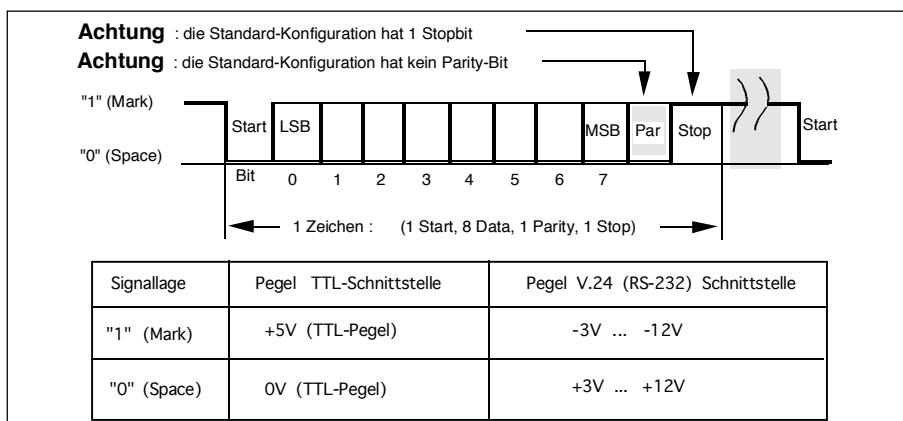

Pin	Signal	Input/Output	Comment
1	TXD_A	I	serial data, print data
2	TXD_B	I	serial data, print data
3	RXD_A	O	serial data for error messages, Xon/Xoff-messages
4	RXD_B	O	serial data for error messages, Xon/Xoff-messages
5	RESET in		reset
6	GND signal		

Pin Assignment Serial RS-422/485 , J 20

The connector for the RS232 interface is a 6 pin Weidmüller Minimate plug-in connector.

6.2 Parallel Interface

6.2.1 Centronics Adapter with SUB-D 25 Pin Connector

The GKA-407 connects the adapter with the printer (to J5).

The GKA-302 establishes a 1:1 connection from the adapter to the parallel port of a PC.



The peripheral devices that are connected to the interfaces and the DC circuits of this printer have to meet the requirements for extra-low safety voltage (SELV) with limited power in accordance with EN/IEC 60950.

6.2.2 PIN Assignment at the 25pin SUB-D Connector of the Adapter

Pin	Signal	Input/Output	Comment
1	Strobe/	I	taking over data DB0 ..7 with the rising edge
2	DB0	I	
3	DB1	I	
4	DB2	I	
5	DB3	I	
6	DB4	I	
7	DB5	I	
8	DB6	I	
9	DB7	I	
10	/Acknowledge	O	
11	BUSY	O	becomes high with the falling edge of /Strobe
12	Paper End	O	see error messages
13	Select	O	see error messages
14	Auto Line Feed	I	can be connected with Select (Windows operation)
15	/Fault	O	see error messages
16	/Input-Prime	I	used to trigger a RESET
17	Select in	I	used for reactivation
18-25	GND digital		

6.2.3 Timing of the Parallel Interface

Time	Name	min (µs)	typ (µs)	max (µs)	Comment
Tack	Ackn.pulse width		17		
Tba	delay Busy-Ackn.			5,5	
Tbs	Busy Setup	0,5			Time before the next Strobe
Tdsu	Data Setup	0,5			
Thold	Data hold	0,5			For open collector control, the minimum time is 3.5 µs. This value can be changed to other values through alternative placement of the RC-filters.
Tsb	delay Strobe-Busy	0,5			
Tstrb	Strobe pulse width	0,5			

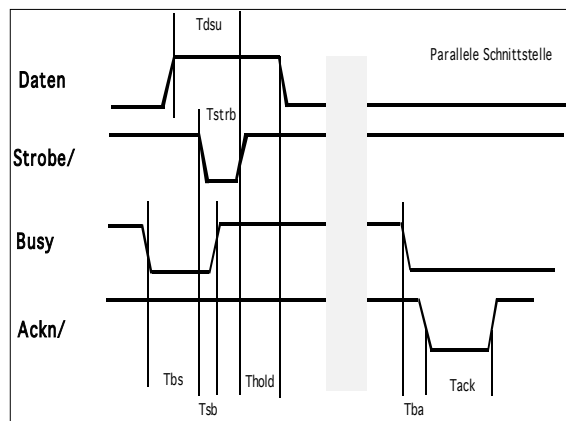

6.3 Infrared Interfaces

The following protocols can be used:

- **IrDA:** IR LPT (printer service)
IR COMM 9 wire (optional)
Also see: www.irda.org
- **GeBE-IR:** simple, error-proof,
bidirectional,
dot-to-dot IR protocol.
GeBE-Doc.No. MAN-D-394

All standard versions of the printer have the hardware for an IR transmitter/receiver installed, so the protocols GeBE-IR and IrDA are available for all standard printers of the series GPT-4454.

The internal IR tranceiver is installed directly below the red foil window (10). It is important to consider that infrared transmission only works "at sight". The radiation angle is about ± 15 degrees. The transfer distance to "IrDA standard power" devices is 1.0 meter.

Use of the Sleep Mode

In the setting "IrDA "or "GeBE IR", the IR receiver will even stay active in the sleep mode, so the device will not have to be switched on explicitly for printing. The power consumption of the printer is only about $25\mu\text{A}$ in this mode. However, the printer should still be turned off during long periods of inactivity.

GeBE -IR Protocol

The GeBE-IR protocol is a simple, error protected infrared protocol. Data transmission is processed in CRC protected blocks.

With each transmission confirmation, the printer status is sent back to the host.

The implementation is very easy to realize. The protocol is disclosed.

IrDA Protocol

The printer works with the protocol service IrLPT. In this service, the printer will not send back any messages.

A bidirectional service "IrCOMM 9 wire" is available on request.

In the menu setting, the selected baud rate represents the maximum baud rate. If 57,600 baud is selected, for

example, the printer will start to communicate with 9,600 baud and then switch up to 57,600 or 38,400 baud, depending on the transmitter.

The maximum baud rate of 115,200 should only be reduced, if transmission errors occur.

When an infrared transmission is interrupted, the printer will look for the transmitting master device for about 20 seconds in order to complete the transmission. After that, the stack is reset, and new inquiries are answered.

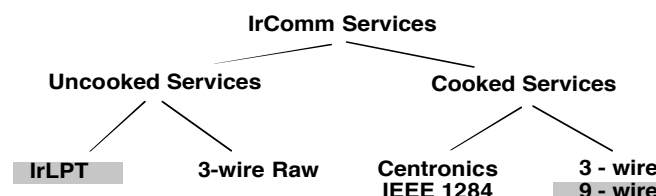

Driver:



Windows 98 / ME / NT / 2000 / XP and

WinCE.NET 4.2 You can find drivers on our Internet page: www.oem-printer.com

Pocket PC drivers are available at :

www.fieldsoftware.com or
www.bachmannsoftware.com

PALM OS, SYMBIAN Series 60

Drivers are available at

www.bachmannsoftware.com

IrDA Data Specification	Complies with: IrDA V1.0 Standard Power SIR			
	min	max		
Radiation input	40	100	mW/sr	On-axis
Min. input radiation intensity		4	W/cm ²	$v < (\pm 15^\circ)$
Peak wave length		870	nm	
Safety	Complies with IEC 825-1 class 1 (EN 60825) eye safety specifica			
Range	0,01	1	m	
IrDA interface parameters	IrDA: automatic setting in accordance with IrDA ; 9,600; 38,400; 57,600; or 115,200 Baud			
GeBE-IR interface parameters	GeBE-IR protocoll: 9,600; 38,400; 57,600; or 115,200 Baud; 8 data bits, non parity, 1 stop bit			

6.4 USB Interface

The GPT-4454-USB meets the USB specification V1.1 for full-speed devices. The printer is compatible with USB V2.0 bus systems. The USB device class is equivalent to a "Vendor Specific Device". Therefore, transmission can be done with virtual COM port drivers. The printer will operate like a serial printer. The virtual COM port drivers are available for the operating systems Windows 98/98SE/ME/2000, and XP. Consequently, standard GeBE printer drivers can be used.

Operation

If a sleep mode has been selected for the printer, it will switch to sleep mode after the preset time period has passed. The USB interface, however, remains active, being fed directly from the USB bus. A new print job with the standard driver reactivates the printer without any loss of data. The USB suspend mode also has the printer-internal USB interface turned off. In this mode, the printer will "go to sleep" after the preset sleep time.

USB Drivers

Windows 98 / ME / NT / 2000 / XP

Windows and USB drivers can be found on the GeBE website. Please read the included installation instructions. Before the initial operation, the matching virtual COM port driver (VCP driver) and the printer driver have to be installed.

Setting the VCP Driver

The example shows the setting with Windows 2000. The procedure is very similar with XP or Windows 98. Starting with the Windows "START" button, select "Settings" -> "System Control" and click on the "System" folder.

Select the "Hardware" tab, and click on "Device Manager".

There, activate the "+" symbol under "Connections (COMand LPT)", and look for the entry "USB Serial Port (COMx)".

Open it and click on "Port Settings", in order to have the settings of the virtual COM port displayed.

It is recommended to use the settings of the virtual COM port according to the settings of the printer: 115,200; n; 8; 1; XON/XOFF.

If the printer is not operated in step mode, "Hardware Flow Control" is recommended.

Click on "Advanced" to see the extended settings. Please make sure that the settings shown below have been carried out.

For Windows 2000 and XP

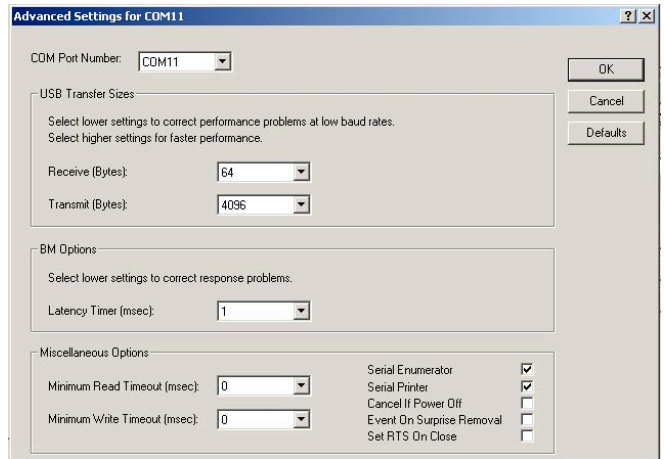

For Windows 98 and ME

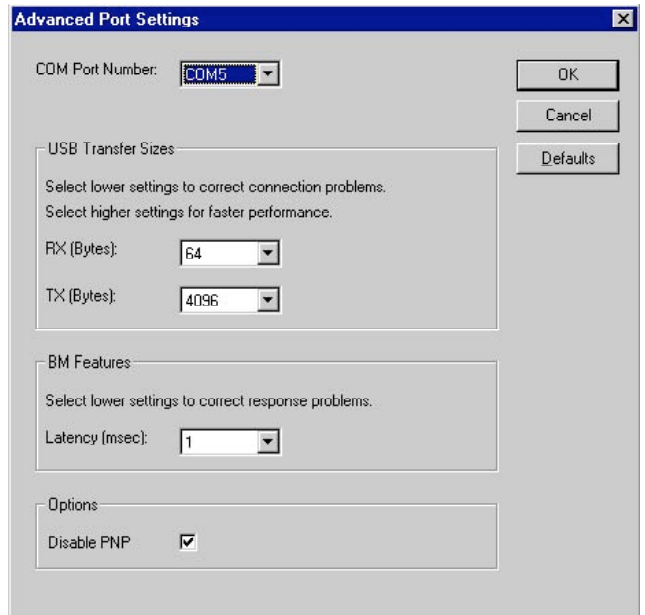

Never activate an action in the printer driver at the end of a job. This can cause a loss of data.

USB specification	V1.1 (V2.0 compatibel)			
Device type	vendor specific device			
USB speed	full speed			12 Mbit/s
Power consumption printe	no printing	min.	typ.	max.
	USB active /printer active		30 mA	
	USB active /printer asleep		25 mA	
	USB suspend / printer asleep		300 µA	

6.5 Bluetooth® Wireless Technology

The GPT-4454-BT meets the BT specification V1.1 class 2, attaining a transmission range of about 10 -15 m, and even further in the free field.

The printer can be operated with a customary Bluetooth® dongle that comes with a virtual Com port driver. An RS232 remote receiver is available on request.

Operation

The printer responds to an inquiry scan with its name "GPT-4454" and its BT address. However, it can also be addressed directly, without a scan, with its BT address.

A "BT connect" activates the printer. The printer will maintain the connection, until it goes into sleep mode. The online power consumption of the printer with an active BT link is about 35 mA. The sleep mode disconnects an active connection and activates the BT sniff mode. In this mode, the printer scans its environment for possible calls every 1.25 seconds. During these inquiry scans, it remains visible and responsive. It will then take about 2-3 seconds to establish a connection. If the printer is addressed directly with its Bluetooth address while in sniff mode, the connection is established within milliseconds.

The power consumption in this mode is about 1.5 mA. When the printer is reactivated through the feed button, the BT transceiver will remain in sniff mode. The power consumption in this mode is about 7 mA. After the set time period, the printer will go back into sleep mode. We recommend to set the sleep time to "1 minute".

If the printer is not going to be used for several days, it should be turned off with the OFF/NEXT button. When it is turned back on, it will take at least 10 seconds before the printer is ready and can receive data.

The printer will not require any kind of authentication from the master. If your transmitter still requires a PIN number, type in "0000".

Please always set the printer to 115,200; n ; 8; 1.

Drivers:

Windows 98 / ME / NT / 2000 / XP and

WinCE.NET 4.2 You can find drivers on our Internet page: www.oem-printer.com

Pocket PC Drivers are available at :

www.fieldsoftware.com or
www.bachmannsoftware.com

PALM OS, SYMBIAN Series 60

Drivers are available at

www.bachmannsoftware.com



This printer contains a 2.4 GHz radio transmitter. For health reasons, a distance of at least 1.0 cm must be kept between the printer surface and the body of the user, except for hands, feet, and joints. As a precaution, any body contact during operation should be kept to a minimum.

Bluetooth® Specification	V1.1			
Radio transfer level	4 dBm (class 2)			
Range	app. 10 m			
Profile	SPP serial port profile			
Power consumption printer	no printing	min.	Typ.	max.
	active connection / data rate 115 kbps	50 mA	62 mA	95 mA
	active connection/ no data transmission	25 mA	35 mA	55 mA
	idle	18 mA	25 mA	40 mA
	printer active / BT sniff mode	5 mA	7 mA	15 mA
	sniff mode (1.25 sec. scan)	1 mA	1.3 mA	2.5 mA
	power off	0.3 µA	0.7 µA	2.0 µA

CE statement:

The BlueRS+I complies with the European safety regulations IEC 60950, and EMV regulations ETS 300 328-2 and ETS 301 489 -1 and -17.

FCC statement:

The printer contains a BlueRS+I OEM serial adapter with the FCCID: RFR-BRSI / IC: 4957A-BRSI .

The BlueRS+I complies with part 15 of the FCC rules and with RSS-210 of Industry Canada.

The BlueRS+I has been qualified as a product in accordance with the Bluetooth Qualification Program (BQP).

7 Operation



The closed printer is protected against static discharges in accordance with the EMV guidelines. Since the user may come in contact with parts that are electrically sensitive, when the printer is open (like the print head during cleaning, or the electronics during a battery exchange), the user should make sure that all possible static charges are discharged through sufficient grounding of the body before touching the printer (e.g. by touching grounded objects like radiators), in order to safely avoid damage to the printer.

Inserting the Paper Roll

1. & 2. Unwind a few cm of paper from the roll. Keep the layers wound tightly, and open the printer cover by slightly pressing the LEVER in the cover upwards. The cover is now easy to open.
3. Insert the paper roll in the paper storage, so the outside shows toward the printer mechanism.
4. Close the cover by applying strong pressure. You can hear it snap shut. Now you can rip off paper at the tear bar without the cover opening up or the paper sliding through the print head.

Which Thermal Paper is Suitable?

The printer is specified for a paper width of 57.0 ± 0.5 mm, diameter of 31 mm, paper thickness of 60 g/sqm. GeBE is offering suitable paper rolls (GPR-T01-057-031-007-060A; quality: 5 years) as part of the standard program. Other papers may cause failures.

1.



2.



3.



4.

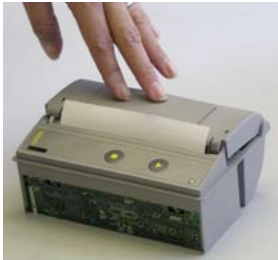

Which side of the thermal paper can be printed on?

On the paper roll, the printable side is the outside in almost all cases. See: Troubleshooting and Recovery on page 22.

Other Types of Paper Offered by GeBE:

High Temperature Paper

begins to blacken at about 100°C (standard: app. 70 °C), making it ideal for applications like parking receipts.

2 Two-Ply Paper

produces a copy of the first layer with the second layer. Optionally, the first layer can be rewound.

Adhesive Labels

are connected with each other through perforation. A mark for correct positioning is located between the labels. This is the only kind of label that can be used with the FLASH printers.

Archival Safe Paper

is a paper that maintains printed images for at least 15 and up to 99 years, if stored in a dark and dry environment.

Two-Color Paper

prints red with the normal setting, black with a higher temperature setting. The temperature can be set by command.

Maintenance, Cleaning

After larger print jobs, depending on the paper quality and adverse environmental conditions, it may be necessary to clean print head, sensor, and platen roll, especially, if some areas are no longer printed properly.

- Open paper supply lid and remove paper roll.
- Loosen dirt particles at paper, sensor, and tear bar with a small brush.
- Blow forcefully into the paper supply compartment in order to remove the coarse dust.
- Soak Q-Tip with isopropanol (IPA) and clean the print head, or use print head cleaning pin / cleaning card.
- Other stubborn debris may also be removed with a Q-Tip (IPA).

20

21

22

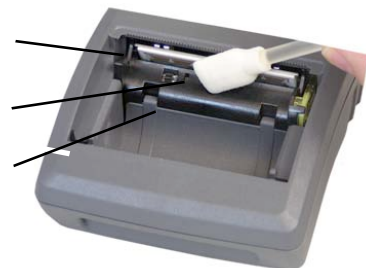

- 20 paper tear bar
- 21 print head
- 22 paper sensor



Never use sharp objects for cleaning. This may damage the print head.

8 Key Functions

Description of the Key Functions

The keys have different functions depending on the status – normal operation or print settings menu. The time for which the buttons are held down is also an issue.

Feed / Enter (5)

Through this button, the printer can be reactivated from sleep mode, and the paper can be transported forward. When the feed button is pressed, the printer will first feed one line of the set font. If the button is held down for more than two seconds, it will feed continuously.

Self Test

By starting a self test printout, the printer functions can be tested. For this purpose, the FEED button (5) has to be held down for at least three seconds, when it is pressed to reactivate the printer from power-OFF. The interfaces are not tested. Software version and character set are printed out. For OEM, special printouts can be activated during the self test.

OFF / NEXT Button (3)

By holding down the OFF/NEXT button for more than three seconds during operation, the processing of batch file T2 is initiated. In the μ -p flash, the command for power-off (after one second) is filed in batch file T2. This way, this button is programmed as OFF button for the printer (controller with power-off mode).

SET Button

Currently without function.

Button FEED/ENTER	Button OFF/NEXT	Action
pressed	not pressed	paper feed by one line
pressed > 2s	not pressed	continuous paper feed
pressed during power-on < 1s	not pressed	reactivation, no paper feed
pressed during power-on paper inserted > 2s	not pressed	call T0 (self test)
pressed during power-on no paper > 2s	not pressed	call hexdump mode
pressed in hexdump mode no paper	not pressed	end of hexdump mode
not pressed	button released after < 1s in normal paper mode	call T1 (default= form feed 1 line)
not pressed	Button held down > 3s	call T2 (default =power-off after 1 second)
pressed	pressed	call print settings menu

9 A Guide Through the OPD-Menue®

The most important printer settings can be easily changed with a few strokes using the OPD-Menues® (OnPaper-Display). Therefore, they can be called at any time and can be quickly comprehended with the menu printout. The inconvenient accessing of DIP switches and the programming through a terminal program are no longer necessary.

The OPD-Menue® is operated with only two buttons (OFF/NEXT and FEED/ENTER).

The OPD Menue® is an editor of the initialization batch file "TINIT". See chapter on batch files.

Button FEED/ENTER	Button OFF/NEXT	Action
pressed	not pressed	increasing the parameter
not pressed	pressed	moving to the next menu item
pressed	pressed	leaving menu and saving settings

Menu Guide - Example:

Bold : menu printouts
 Normal: possible settings
 Italics: comment

Welcome to the OPD menu 1.0 5

Setup timeout after 10 minutes

Actual printer settings:

Ubat: 7,8V

Tbat: 24°C

(displayed only with battery present)

Firmware: GE-xxxx

Density 25
Speed: med (104)/low
Interface: RS232/USB/Blue
COM: 115.200,n,8,Tx+
Sleep time: 1 min
Font #: 1
Char. format: D0,W0,H0,S0,104

? Change actual settings

Press ENTER to change
 Press NEXT to skip
 Press NEXT+ENTER to save and exit

PRINTER SETUP:

Press ENTER to modify
 Press NEXT to store and continue
 Press NEXT+ENTER to save and exit

Density:	25	20, 25, 30, 35, 40, 45, 50, 90(2ply)
Speed/Quality:	med 104/ low	low (32)/ low, low (64)/ low, med (104)/ high, med (104)/med, med (104)/ low, high (144)/ low,
Interface:	RS232/USB/Blue	RS232/USB/Blue, IrDA, GeBE-IR, GeBE-COM
Baud rate:	115.200	1200, 2400, 4800, 9600, 19200, 38400, 57600, 115200.
COM parameter:	n,8,Tx+	n, 7, Tx+ / o, 7, Tx+ / e, 7, Tx+ / n, 8, Tx+ / o, 8, Tx+ / e, 8, Tx+ / n, 7, Tx- / o, 7, Tx- / e, 7, Tx- / n, 8, Tx- / o, 8, Tx- / e, 8, Tx-
Sleep Time:	1 min	OFF, 5 sec, 30 sec, 1 min, 10 min, 1 h, 12 h, 32 h
Font #:	1	1, 2, 3, 4
Text orientat:	Text mode (D0)	Text mode (D0), Data mode (D1)
Char. size :	W0/H0	W0/H0, W0/H1, W0/H2, W0/H3, W1/H0, W1/H1, W1/H2, W1/H3
Char. spacing :	0	0,1,2,3,4,5,6,7
Print width :	104 mm	104 mm, 88 mm

? Return to default settings

Press ENTER to change
 Press NEXT to skip
 Press NEXT+ENTER to save and exit

ONLY, when clock is included or connected

17.03.03 17:33

? Change date / time

Press ENTER to change

Press NEXT to skip

Press NEXT + ENTER to save and exit

RTC SETUP:

Press ENTER to modify

Press NEXT to store and continue

Press NEXT+ENTER to save and exit

00 .. 49 **Year:** 03

01 .. 12 **Month:** 11

01 .. 31 **Date :** 14

01 .. 07 **Day :** 7

00 .. 23 **Hour :** 13

00 .. 59 **Minute :** 33

1 00 : 00 ON

? Change alarm

Press ENTER to change

Press NEXT to skip

Press NEXT + ENTER to save and exit

ALARM SETUP:

Press ENTER to modify

Press NEXT to store and continue

Press NEXT+ENTER to save and exit

01 .. 07, * **Day :** 7 * : means periodic operation, e.g. if * is selected for "day",
the alarm is called every day at the set time

00 .. 23, * **Hour :** 13

00 .. 59, * **Minute :** 33

ON, OFF **Mode:** OFF

10 Jumper for Power-Down Mode Setting

	Name	Meaning	Comment
J3	power-down mode	determines together with R37 or Br9, if idle mode, sleep mode, or power-off mode is used	standard: plugged in = idle mode in connection with R37 (power-off mode without R37 or Br9). open = sleep mode

11 Status Messages Through LEDs

LED "STATUS" (green) (6)

The STATUS LED will flash, when everything is in order. It will flash red in case of a failure. During fast charging, the green STATUS LED will flash, while it permanently glows during trickle charge.

LED "IR Communication" (red) (7)

During data transmission, this LED will glow red under the IR window.

Status Messages of the Printer Through the Interfaces

Besides the optical status messages displayed by the three LEDs on the control panel of the printer, messages are also transmitted through the serial interface. Most of the time, they are sent as single ASCII characters that can be analyzed by the host.

Status Messages	Serial Interface				Comments	
	feedback through the serial interface		on:off /flash frequency fast: "S" app. 0.66Hz medium: "M" app. 0.33Hz slow: "L" app. 0.16Hz			
			Status LED			
faultless operation			1:31 / M	green		
after reset	"R"				level on status lines only short-term during phase of initialization; message: <XON> "R" "X" (or error)>	
after watchdog reset	"R"				crashing program	
error end	"X"				also after hardware, software, and watchdog- resets	
buffer empty	X ON				buffer emptied by 32 characters <DC1> = \$11	
buffer full	X OFF				space for 22 more characters in buffer <DC3> = \$13	
synchronous feedback	alle Zeichen				processing of sunchronizing commands; each transmitted character	
charging battery						
formatting		"L"			off	L := charge start l := end of charge
fast charge	"I"	"L"			LED permanently on	L := charge start l := end of charge
trickle charge	"f"	"F"	LED flashes (1:3)	F := charge start f := end of charge		
errors	start	error end				
paper end	"P"	"p"	1:1 / S	red	After paper has been inserted, the printer waits for about 1sec before printing, in order to allow for enough timefor the mechanism to be closed.	
temp. low	"K"	"k"			print head temperature too low	
temp. high	"T"	"t"			print head temperature too high	
Vp too high	"M"	"m"				
parity error	"?"		1:31 / M	green	parity or framing error / no interruption of printing	
EE-OK	"E0"				EEPROM command completed without errors	
EE-invalid	"E1"				invalid text file no.	
EE-password	"E2"				wrong password for EEPROM access	
EE-overflow	"E3"				text file memory overflow	
EE-time-out	"E4"				programming time for EEPROM byte exceeded	
EE-KO	"E5"				EEPROM not located	
			IR communication			
IR reception			LED on	red		

12 Batch Files

Almost all commands that the printer can receive through the interfaces and then performs can be entered in the batch files. When a batch file is processed, the commands it contains are added to the data stream of the print program sequentially, as if they were coming through the interface from outside. This way, all settings that can be done by command can be processed via batch file. Besides settings commands, batch files can also contain text and graphics.

The file structure consists of one TMenu and a TINIT, which are both processed with each system boot-up, as well as 10 files that can be used freely and can be retrieved by command. Some of these files can be addressed through additional events. If the controller has an EEPROM, it contains a file structure that is identical to that of the program memory (flash).

When a file is retrieved, the printer will check, if it contains data in the EEPROM. If not, the file will be processed in the flash. This allows flash files to be overwritten. Flash files can only be changed at the factory.

Factory Settings Allocated in the Flash Memory:

- "TINIT" ...settings after hardware RESET
- "T0 "self test through FEED button after reset
- "T1 "form feed through NEXT button <1sec.
- "T2 "power-off through OFF button >3sec.
- "T3 - T9" : unused

Text or Graphics, Batch Files in the EEPROM

For the printing of text and graphics, the GPT-4454 has an 8 KB EEPROM (app. 6 KB can be used for logos) and the GPT-4454 has a 32 KB EEPROM (app. 30 KB can be used for logos).



ATTENTION! By using these files in the EEPROM, you are changing the standard factory settings.

It is recommended to store logos PCL compressed. By using the Windows driver, compression rates of app. 3 - 4:1 can be achieved.

For comparison: Uncompressed full graphics of 5 cm length take up 40 KB, or app. 11.4KB compressed.



Creating and Saving Logos:

A special printer driver is available for creating logos.

Configuration of the Printer with TMenu and TINIT

After a hardware RESET (connecting the power supply), the printer will check for a described TMenu and/or TINIT in the EEPROM. If the search is successful, it will process the commands in these batch files, and will then be ready for operation. If not, the TMenu and/or the TINIT will be processed in the Flash with the factory settings.

TMenu:

The OPD-Menu[®] is a printer function that allows the user to edit the TMenu in the EEPROM. The TMenu can only be changed through this menu.

Structure of the TMenu:

```
<ESC>Y<18h> {density}
<ESC>[<DEZ104><DEZ48> {power consumption}
<ESC>]<DEZ115><DEZ40> {baud rate, settings}
<ESC>e<DEZ5><DEZ2> {power-down time}
<ESC>P1 {font}
<ESC>D0 {text orientation}
<ESC>W0<ESC>H0 {text size}
<ESC>S0 {text spacing}
<ESC>h104 {print width}
```

TINIT:

The TINIT is always processed subsequent to the TMenu. In the TINIT, other presets that were not incorporated in the menu can be executed. It also allows settings to be blocked in the menu by repeating them here.

The following TINIT file is an example of a file that can be modified by the user. It is available for downloading from the Internet at the URL: www.oem-printer.com/flash.

The file will erase the TINIT, while printing out all actions in italics at the same time. Any commands can be entered in der TINIT.



If a command of the TMenu is repeated in the TINIT, this value can no longer be changed through the menu.

Erase Tinit ...

```
<ESC>uUERAS
```

Special Number S-??? / Status 24nov03

```
Programm Tinit mwithGE-xxxx...
```

{Comments}

```
<ESC>s@PROG<00h><11h>
```

```
<ESC>r1<28h><3Ch><01h><12h> {charging parameters}
```

```
<A9h><01h><3Ch><01h><40h>
```

```
<19h><01h><85h><0Ah><8Ch>
```

All programmed!

13 Option Magnetic Card Reader

The magnetic card reader GPT-4454 can be used for magnetic cards of the type ISO 3554. It reads up to 3 tracks simultaneously. The permissible swiping speed is 10 - 100 cm/s.

The recording density and the number of bits per character differ from one track to the next in accordance with ISO 3554. They determine the maximum number of characters including start and stop characters that can be recorded on each track:

track	bpi	bit	character
1	210	7	79
2	75	5	40
3	210	5	107

In accordance with the norm, track 1 and 2 are only read during operation, while track 3 is also used for recording.

Operation

After the swiping of the card, the LED lights up for about 2 seconds, if the card was read correctly. If an error occurred, the LED will flash rapidly 3 times. While the LED is on, another reading process is not possible. After the LED has gone out, the internal buffers are getting ready for a new reading process, waiting for a new card to be swiped.

The printer puts out the card data for each track with a header. The data set is concluded with a check sum.

The card data per track contain:

- the number of data on this track
- status byte (type of error, if available)
- data

A detailed description can be found in the software manual.

Applications

- Track 1 and 2 for credit cards
- Track 2 and 3 for Eurocheque
- Track 2 for access control
- Track 3 for time recording

Numeric Characters Track 2 and 3

P 3210	corresp.	meaning
1 0000	0	
0 0001	1	
0 0010	2	
1 0011	3	
0 0100	4	
1 0101	5	
1 0110	6	
0 0111	7	
0 1000	8	
1 1001	9	
1 1010	:	control
0 1011	;	start sentinel
1 1100	<	control
0 1101	=	field separator
0 1110		control
1 1111	?	end sentinel

EC Card		
Track	Position	Content
2	1-3	identification 672
2	9-18	account no.
2	21-22	year of expiration
2	23-24	month of expiration
3	1-4	identification (0159, EC card)
3	5-12	bank identification code
3	14-23	account no.
3	37-40	remaining amount for withdrawal
3	41	final digit of the year of the last withdrawal
3	61-62	year of expiration
3	63-64	month of expiration
S-Card		
Track	Position	Content
2	x	like EC card
3	1-4	identification (0059, S-card)
3	9-24	like EC card
Credit Card		
Track	Position	Content
1	2-17	credit card number
1	19-44	card holder's last name
1	46-47	year of expiration
1	48-49	month of expiration
2	1-16	credit card number
2	18-19	year of expiration
2	20-21	month of expiration

ALPHA Character Track 1					
P 543210	hex			hex	
1 000000	00	space	0 100000	20	@
0 000001	01	!	1 100001	21	A
0 000010	02	..	1 100010	22	B
1 000011	03	#	0 100011	23	C
0 000100	04	\$	1 100100	24	D
1 000101	05	%(start)	0 100101	25	E
1 000110	06	&	0 100110	26	F
0 000111	07	'	1 100111	27	G
0 001000	08	(0 101010	28	H
1 001001	09)	1 101011	29	I
1 001010	0A	*	1 101000	2A	J
0 001011	0B	+	0 101001	2B	K
1 001100	0C	,	0 101100	2C	L
0 001101	0D	-	1 101101	2D	M
0 001110	0E	.	1 101110	2E	N
1 001111	0F	/	0 101111	2F	O
0 010000	10	0	1 110000	30	P
1 010001	11	1	0 110001	31	Q
1 010010	12	2	0 110010	32	R
0 010011	13	3	1 110011	33	S
1 010100	14	4	0 110100	34	T
0 010101	15	5	1 110101	35	U
0 010110	16	6	1 110110	36	V
1 010111	17	7	0 110111	37	W
1 011000	18	8	1 111010	38	X
0 011001	19	9	0 111011	39	Y
0 011010	1A	:	0 111000	3A	Z
1 011011	1B	;	1 111001	3B	[
0 011100	1C	<	1 111100	3C	\
1 011101	1D	=	0 111101	3D]
0 011110	1E	>	0 111110	3E	^(field)
0 011111	1F	? (end)	1 111111	3F	_

14 Character Sets

The four character sets in the flash memory of a standard controller can be selected by command. Other character sets on request. The Euro character is located at 16 hex.

GeBE Standard Character Set: Resembles IBM II Code Table 850



Font Sizes of the Character Sets

Font No.	Dots (Horiz/Vert)	Characters/Line
1	16 / 24	52 (not IrComm 9 wire)
2	9 / 22	92
3	7 / 16	118
4	12 / 24	69

Optional Character Set: Cyrillic

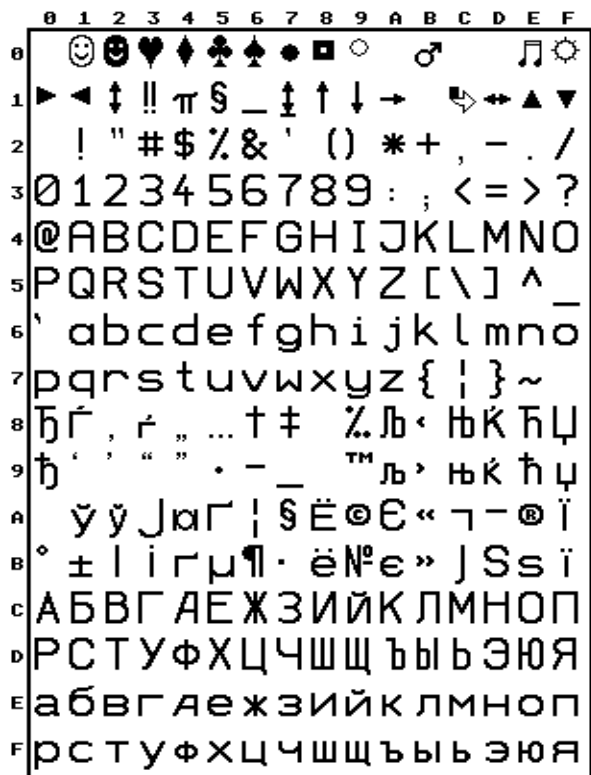

Optionally Available Character Sets

The following character sets are available at this time and can be programmed into the FLASH memory of the μ -processor in exchange for other character sets. Please send us your inquiry. GeBE will gladly create other character sets on request.

	Dots (Horiz/Vert)	Characters/Line
IBM II	16x24	52
IBM II	14x 22	59
IBM II	11x22	75
IBM II	9x 22	92
IBM II	7x16	118
IBM II 90°	16x11	
Kyr	16x24	52
Kyr	14x 22	59
Kyr	11x22	34

15 Accessories and Spare Parts

Art. No.	Art. Name	Description
12028	GPR-T01-114-060-025-080A	thermal paper rolls
10258	GKA-245-1-500	power supply cable 10-20 or 18-36 VDC
12082	GKA-517-500	power supply cable 4.5 - 8.5 VDC
10586	GKA-302	connecting Centronics adapter to PC
11975	GKA-484-1-2000	charging cable, one end open
10589	GKA-304-2-2000	RS232 data cable, one end open
11352	GKA-406	RS232 data cable on D-SUB 9 pin to PC
11406	GKA-407	Centronics adapter cable to printer
11919	GKA-480	USB data cable on USB type A to PC
12333	GNA-6,0V-1,6Ah-NiMH-Pack-070	NiMH battery pack 5 cells 1,600 mAh
12332	GNG-7,5V-0.9A.U	plug-in power supply
10473	GNG-5V-5A-AC *	open frame power supply 5V 5A *
11582	GNG-24V-3A-AC *	open frame power supply 24V 3 A *

OEM Options for the Printer

- custom housing color, design foil
- program versions and special character sets
- large EEPROM: up to 32 KB
- magnetic card reader: three tracks simultaneously
- SPI-BUS extensions (e.g. keyboard, LC display)
- paper rewinder
- external power supply
- operation with externally charged batteries



* The listed open frame power supplies are **ONLY** approved for factory connection in accordance with UL60950.

16 Service

Documents for the System GPT-4454 MAXI MULDE

All further documents are listed on the Internet at www.oem-printer.com/flash. You can request the software manual SoMAN-E-485 (English) or -D-484 (german) or directly from GeBE via email (sales.ef@gebe.net).



Service (GeBE Technical Support)

For service or questions, please contact:

GeBE Elektronik und Feinwerktechnik GmbH, Beethovenstr. 15 • 82110 Germering • Germany • www.oem-printer.com • Phone: 0049 (0) 89/894141-0 • Fax: 0049 (0) 89/8402168 • Email: sales.ef@gebe.net



Further Information

Further information on the GeBE MAXI MULDE series is available at www.oem-printer.com/. At this address, you can also find a personal consultant you can turn to with your questions. Or simply send an **email** to the GeBE **sales team** at sales.ef@gebe.net. For orders you can use this **fax** number: **0049 (0) 89/894141-33**

17 Troubleshooting and Recovery

Not every failure means that there is an error that cannot be cleared by the user himself. You will save time and money by recognizing and fixing simple errors on your own. The following tips are meant to help you with this:

Hardware RESET: Triggered by holding down the OFF/NEXT button for more than three seconds. This will set the printer according to the TINIT located in the batch file.

Test printout: Triggered by holding down the FEED button for more than three seconds after reactivating the printer from power-OFF (turning off with the OFF/NEXT button).

Hexdump mode: Triggered by holding down the FEED button for more than three seconds after reactivating the printer from power-OFF, if no paper is inserted. After the paper has been inserted, the printer will print the data it receives as hex numbers with the appropriate ASCII code without interpreting the data. This shows, which information the printer "reads" from the incoming data. In order to leave the HEXdump mode, the FEED button has to be held down for at least three seconds, while the paper is removed. After it leaves the HEXdump mode, the printer will process the TINIT for reinitialization.

Symptom	Possible Cause	Remedy
Power Supply		
The printer seems to be printing. Paper is transported, but is not blackened.	Paper: Wrong side toward print head. Only one side of the paper can be printed on.	Insert paper correctly. The thermosensitive side should be turned to the outside of the roll (most of the time). Try the finger nail test: Drag the tip of a finger nail across the paper, pressing down. The friction heat causes the thermosensitive side to blacken.
Printer cannot be activated by pressing the FEED button	No power. Rechargeable battery: not charged Batteries: not inserted, empty	Check power supply. Charge batterie. The green LED should light up no later than after one minute.
At the beginning of printing, the LED goes out just briefly	The power supply is not optimal.	External power supply: Use power supply with sufficient dimension and short feed lines. Check all connections for possible transfer resistances. Since high peak currents occur with thermal printers, even the smallest transfer resistances can result in intolerable voltage drops. In this case, no power supply would be strong enough.
The printer only prints a few dots in one line	Battery: not charged	
The paper feed works, but the self test does not.	External power supply: Cross-section of the power feeding lines too small, current output of the power supply too low.	
The printer only prints a few characters in one line. If more is entered, it stops printing completely.		
Serial Interface		
After a few characters, the printout starts to be incomplete.	The printer buffer is "over-run" (256 bytes), causing a loss of data. The print data transmitter shows no reaction to handshake.	Us or check handshake. (software: Xon/Xoff or hardware: CTS). If necessary: slow down transmission speed, e.g. down to 1,200 baud.
The printer prints the wrong characters.	Interface problem. The transmission is faulty. (Characters of the upper area are printed).	Use correct interface level. (RS232, TTL?). The transmission cable may be too long.
	Wrong data format was set. ("?" is printed of ten).	Select the correct baud rate through the menu. Check data format.
	External power supply: Bad ground connection that causes a part of the printing current to flow through the interface cable. This leads to an increase in potential there, which results in data corruption.	Check and improve ground connection. Feed current through short, thick lines.
	Host sends a break signal after print job (only "?" are printed).	Turn off "framing error ".
IrDA		
The printer prints extremely slow, when high baud rates are selected.	Host ignores turn-around time specified by the printer	Select lower baud rate
Bluetooth		
The printer cannot be found in the BT network.	Possible undervoltage at the BT transmitter or the printer	Restart transmitter. Turn off printer and wait for app. 5 seconds. Switch printer back on and wait for about 10 seconds. Then search again.
USB		
The printout stops after a short time or is repeated constantly.	Wrong COM port settings, or "job end" action activated in Windows driver	Set virtual COM port according to installation instructions. Deactivate "job end" action in Windows driver.

18 CE Certification

The failure-free operation of the printer (assessment criterion A) is achieved, when all printed information remains recognizable in case of a short-term failure, and the printer, on the other hand, automatically returns to its normal functional status afterwards.

The Declaration of Conformity is available on request.

Component	CE	In particular
Printer	CE	see Declaration of Conformity
Bluetooth Transmitter (RS+I)	CE	IEC 60950 / ETS 300 328-2 / ETS 301 489 -1, and -17 FCC Rules Part 15 / RSS-210
IrDA Transmitter		in compliance with EN 60825 (IEC 825-1 class 1 eye safety specifications)

DECLARATION OF COMFORMITY

in compliance with EN45014

KONFORMITÄTSERKLÄRUNG

in Übereinstimmung mit EN45014

Supplier: **GeBE Elektronik und Feinwerktechnik GmbH**
 Anbieter:

Address: **Beethovenstr.15**
 Anschrift: **82110 Germering**
Germany

Products: beginning with Serial Number: **0509xxxx**
 Produkte: beginnend mit Seriennummer: **0509xxxx**
GPT-4454-V.24-DC/DC (standatd and/und S364)
GPT-4454-Ir-BT
GPT-4454-USB

The Products described above are in conformity with:

Die oben beschriebenen Produkte ist konform mit:

EMC Directive / EMV Richtlinie89/336/EWG

Information technology equipment

Einrichtungen der Informationstechnik

Radio disturbance characteristicsEN 55022 1998

Funkstöreigenschaften

Immunity characteristics.....EN 55024 2003

Störfestigkeitseigenschaften

Low Voltage Directive / Niederspannungsrichtlinie:73/23/EWG

Information technology equipment -SafetyEN 60950-1:2001

Einrichtungen der Informationstechnik-Sicherheit

Germering, the 08/22/2005, den 22.08.2005

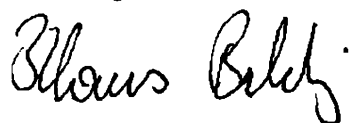

Klaus Baldig

Head of R&D/ Leiter der Entwicklung

GeBE Elektronik und Feinwerktechnik GmbH GKV 027-1

19 Technical Data

GPT-4454	
Print procedure	completely fixed thermal print line
Paper /print width/ diameter/thick-	thermal paper: 113.5 ± 0.5 mm / 104 mm / max.150 mm / app. 45 m at 60 g/sqm / 60 - 80 g/sqm
Resolution	8 dots / mm (203 dpi) , 832 dots / print line
Print Speed	up to 50 mm/s / 16 lines/s line/ 3 mm, i.e. 24 lines high
Layout options	text; graphics, text/data mode; bar code; gray on white; inverted white on black, characters spread in height and width
Character sets, cpl	52 (69, 92, and 118) to select via control command or menu
Bar code	code 39, 2 of 5 int, EAN13, EAN8
RS232 /TTL interface parameters	serial RS232 (option TTL) baud rates: 1,200; 2,400; 4,800; 9,600; 19,200; 38,400; 57,600; 115,200 (DC/DC version: no 1,200 bps) dat bits: 7, 8 stop bits: 1, 2 parity: non, odd, even handshake: hardware and XON / XOFF
Infrared interfaces / interface parameters	GeBE IR protocol: 9,600; 38,400; 57,600; or 115,200 baud, 8 data bits, non parity, 1 stop bit IrDA: automatic setting acc. to IrDA ; 9,600; 38,400; 57,600; or 115200 baud
Magnet card reader (option)	magnetic card reader, ISO3554, 3 tracks
Batch files	Text and gaphics (logo printing); presetting of parameters through menu
Data compression	(PCL) factor app. 3 :1 (for graphic commands); PC compatible; Windows driver
Supply voltage	4.5-8.5VDC through Molex 5 pin connector
Supply voltage DC/DC	10-20 or 18-36 VDC (8-40 VDC max. short-term) through Phoenix connector
Rechargeable batteries	battery pack 5x NiMH cells, 1,600 mAh • option for OEM: Li-Ion battery
Charger for GPT-4454	uncontrolled plug-in power supply 7.5V, 900 mA
Max. current during printing	Can be limited to max. 0.7A - 6A by command (adjustment to operating voltage)
Standard current consumption	online idle mode: typ. 5 mA; sleep mode: typ. 25 µA; power-off- mode: < 1 µA
Current consumption BT	online idle mode: typ. 30 mA; sleep mode: typ. 1.5 mA; power-off- mode: < 1 µA
Current consumption USB	online idle mode: typ. 10 mA; sleep mode: typ. 25 µA; power-off- mode: < 1 µA
Environment	0 °C to 50 °C (-10 °C to +60 °C with GeBE HQ paper) 10% to 80% rel. humidity, no moisture condensation
MTBF	50 km printed paper (on paper specified by GeBE)
Dimensions in mm	119 mm x 68 mm x 143 mm
Weight	app. 500 g incl. paper roll
Housing	PA6 with 15% glass fiber, similar to RAL 7015
Standards/ printer	see declaration of conformity

18 Mechanical Dimensions

